

## Velocity Measurement for Solids

PROCESS MONITORING SYSTEMS FOR SOLIDS

### Product Information

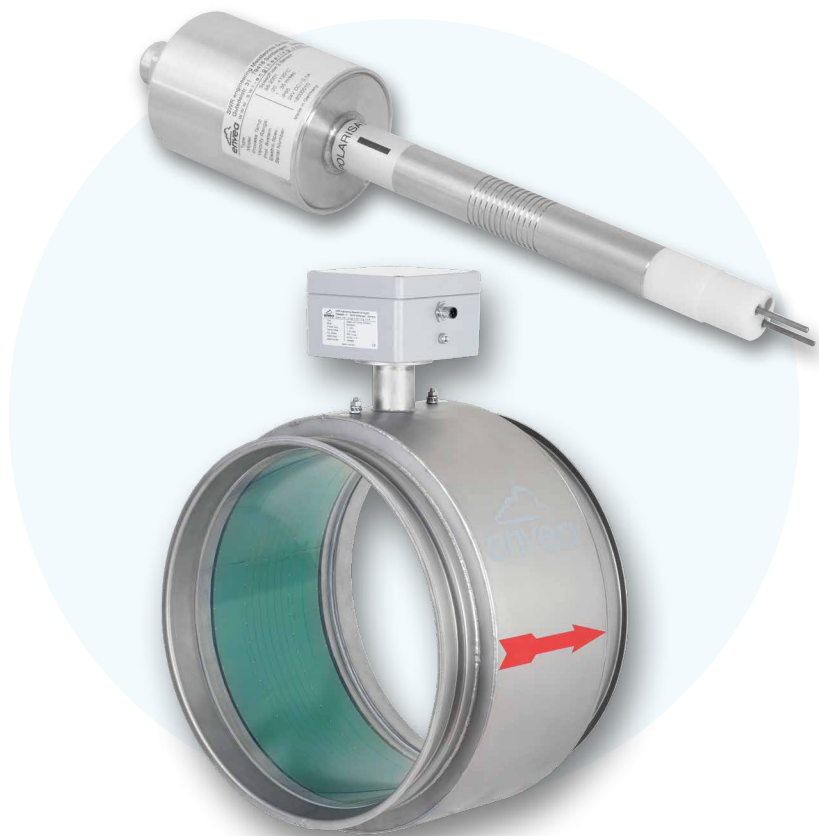

#### FEATURES:

- usable in free fall and in pneumatics
- continuous speed measurement of solids (powder, granules, dust) in metal pipes
- Measurement directly in the conveying stream / entrained flow
- Measurement is completely independent of material
- simple retrofitting

# TECHNOLOGY

## COMMITMENT

SpeedFlow 2.0 has been specially developed for the continuous speed measurement of solids such as granules, powder and dust in metal pipelines.

As the measurement is taken directly in the stream of material, the material can be measured during free fall or while being transported on pneumatic conveyors.

The measurement is completely independent of the material itself. Its range of application starts at material speeds of 0.75 m/s.

By using the Pipe-Version, there is no direct material contact with the electrodes.



## FUNCTION

The measurement of SpeedFlow 2.0 based on electro-dynamics. Thus, the passing and impingement of the solid particles lead to a charge transfer (induction voltage).

These electrical signals are supplied to the correlator, which precisely calculate the transit time between the two electrodes. Due to the defined distance between the two electrodes the speed can be determined.

Commissioning takes place in the installed state and by using of the supplied software.

The speed is displayed as a 4 ... 20 mA signal.

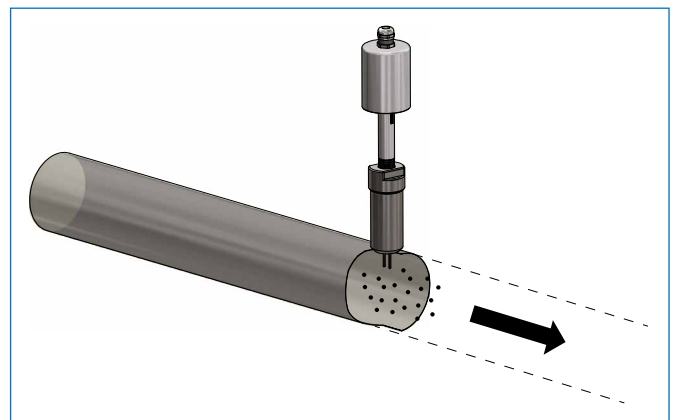

## SYSTEM

A complete measuring point consists of the following components:

### Pipe version:

- Sensor in pipe version with flare connection: DN: 80 / 100 / 150 / 200 / 250 / 350
- Evaluation Unit DIN rail or field housing
- Software
- Optional: C1-box

### Rod version:

- Weld-on socket, including sealing plug
- Sensor with 2 m cable
- Evaluation Unit DIN rail or field housing
- Software
- Optional: C1-box

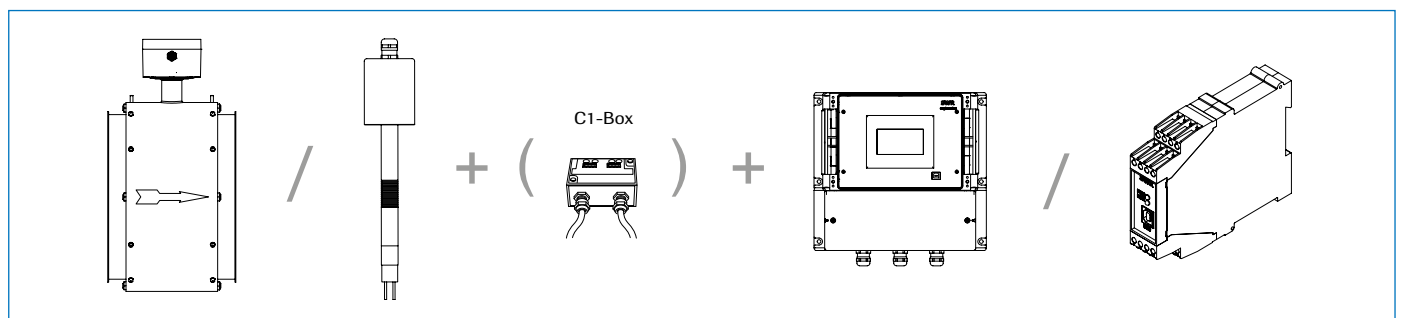

## MOUNTING AND INSTALLATION

For mounting the sensor, the installation location is determined according to the required inlet and outlet sections.

The SpeedFlow 2.0 sensor in the tube version comes with a flare connection and can be easily inserted into an existing pipe system.

Alternative adapters can be purchased via ENVEA Process.

For the SpeedFlow 2.0 in the rod version, the weld-on socket is mounted at the specified installation location and a 20 mm borehole is drilled through the socket and through the pipe wall.

Then the sensor is adapted to the wall thickness, inserted and fixed with the help of the union nut.

The distance between sensor and evaluation unit must not exceed 300 m.

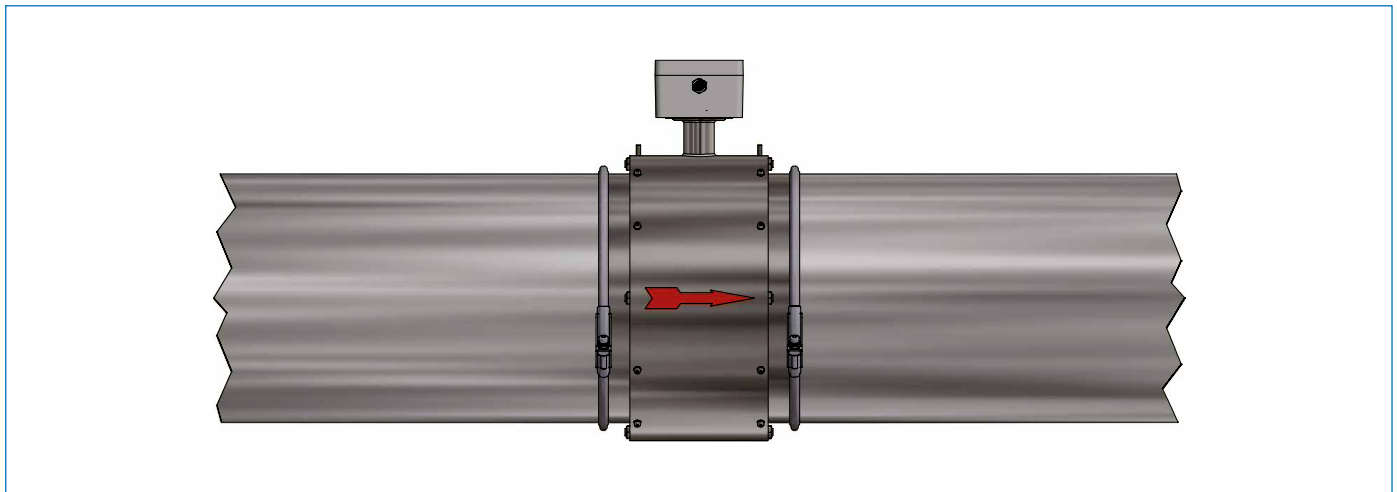
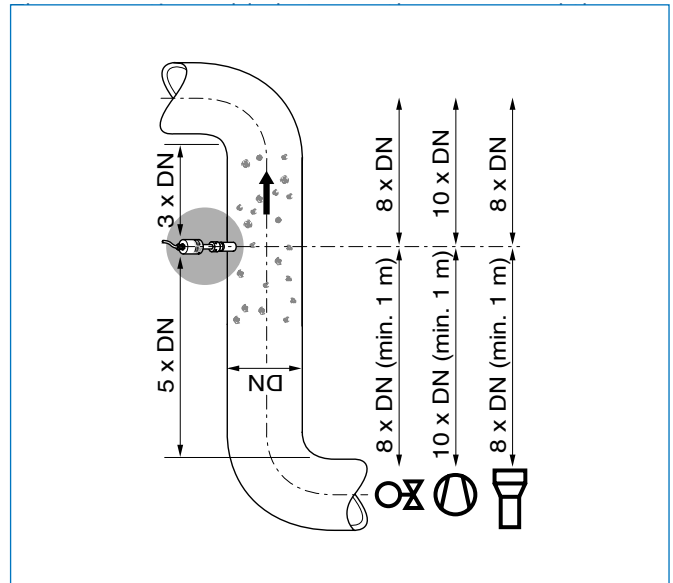

## START-UP PROCEDURE

Commissioning of the measurement takes place via an evaluation unit in the field housing or DIN Rail housing.

Both evaluation units can be parameterized via software.

The PC software offers a input of parameters such as measuring range, required physical units or measuring signal attenuation.

At the evaluation unit in the field housing, the parameterization could be carried out additionally without software on the touch display.

For signal output, a change-over relay contact, ModBus and a current output 4 ... 20 mA are available.

The menu language (German, English or French) can be freely selected on the display as well as in the software.

## TECHNICAL DATA

### Sensor in pipe version

|                             |   |
|-----------------------------|---|
| Innerdiameter               | DN: 80, 100, 150, 200, 250, 350<br>(other sizes on request) |
| Material inner pipe         | PMMA  |
| Mechanical connection       | Flare connection  |
| Protection category         | IP54  |
| Max. pressure               | 100 mbar  |
| Velocity range              | 1 ... 35 m/s  |
| Temperature inside the pipe | 0 ... +50 °C  |
| Temperatur outside the pipe | 0 ... +45 °C  |
| Power supply                | 24 V DC   |
| Weight                      | Depend on diameter  |
| Measuring accuracy          | ± 1 %<br>in the calibrated measuring range                  |

### Evaluation Unit (DIN Rail)

|  |   |
|--|---|
| Power supply                             | 24 V DC ±10 %   |
| Power consumption                        | 20 W / 24 VA  |
| Protection type                          | IP40 to EN 60 529   |
| Ambient operating temperature            | -10 ... +45 °C  |
| Dimensions                               | 23 x 90 x 118 mm (W x H x D)  |
| Weight                                   | Approx. 172 g   |
| DIN rail fastening                       | DIN 60715 TH35  |
| Interface                                | RS 485 (ModBus RTU) / USB   |
| Connection terminals cable cross-section | 0.2 - 2.5 mm <sup>2</sup> [AWG 24-14]   |
| Current output                           | 1 x 4 ... 20 mA (0 ... 20 mA),<br>load < 500 Ω (Active)   |
| Pulse output                             | Open collector - max. 30 V, 20 mA   |
| Relay contact                            | Max. rated load: 250 V AC<br>Max. peak current: 6 A<br>Max. rated load 230 V AC: 250 VA<br>Max. breaking capacity DC1:<br>3/110/220 V: 3/0.35/0.2 A<br>Min. switching load:<br>500 mW (10 V / 5 mA) |
| Data backup                              | Flash memory  |

### Sensor in rod version

|                             |   |
|-----------------------------|---|
| Weld-on socket              | St52 or steel 1.4571                              |
| Rod                         | Wolframcarbid                                     |
| Housing                     | Steel 1.4571                                      |
| Protection category         | IP65 to EN 60529/10.91                            |
| Rod length                  | 15 mm   |
| Velocity range              | 0.75 ... 35 m/s                                   |
| Temperature inside the pipe | -20 ... +80 °C<br>(higher temperature on request) |
| Temperatur outside the pipe | 0 ... +60 °C                                      |
| Power supply                | 24 V DC   |
| Weight                      | Approx. 1.5 kg                                    |
| Dimensions                  | Ø 60, Ø 20, L 320 mm<br>(incl. rod length)        |
| Measuring accuracy          | ± 1 %<br>in the calibrated measuring range        |

### Evaluation Unit (field housing)

|  |   |
|--|---|
| Power supply                             | 110 / 230 V AC 50 Hz<br>(optional 24 V DC)  |
| Power consumption                        | 20 W / 24 VA  |
| Protection type                          | IP65 to EN 60 529/10.91   |
| Ambient operating temperature            | -10 ... +45 °C  |
| Dimensions                               | 258 x 237 x 174 mm (W x H x D)  |
| Weight                                   | Approx. 2.5 kg  |
| Interface                                | RS 485 (ModBus RTU) / USB   |
| Cable screw connectors                   | 3 x M20 (4.5 - 13 mm Ø)   |
| Connection terminals cable cross-section | 0.2 - 2.5 mm <sup>2</sup> [AWG 24-14]   |
| Current output                           | 3 x 4 ... 20 mA (0 ... 20 mA),<br>load < 500 Ω (Active)   |
| Pulse output                             | Open collector - max. 30 V, 20 mA   |
| Relay contact                            | Max. rated load: 250 V AC<br>Max. peak current: 6 A<br>Max. rated load 230 V AC: 250 VA<br>Max. breaking capacity DC1:<br>3/110/220 V: 3/0.35/0.2 A<br>Min. switching load:<br>500 mW (10 V / 5 mA) |
| Data backup                              | Flash memory  |

