



700 GAS DIVIDER



OPERATORS' MANUAL

OPERATING MANUAL

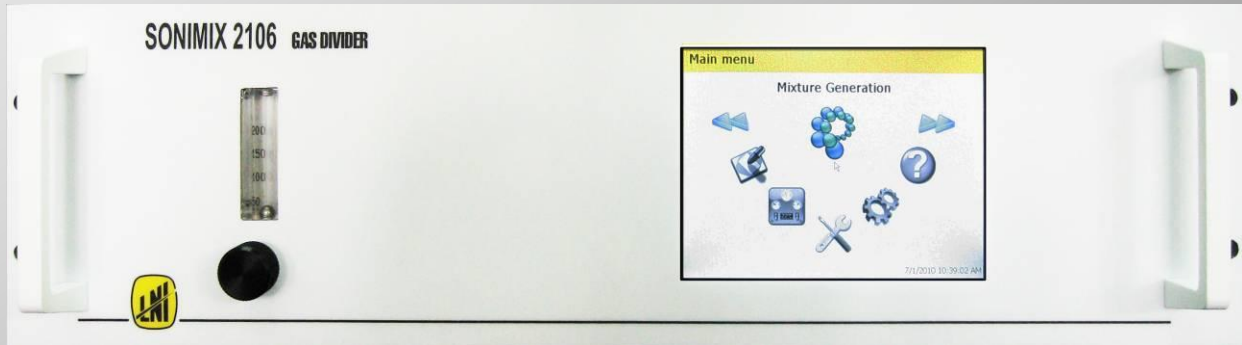

SONIMIX 2106-x-LCD

This Operating Manual is applicable for the following models :

- SONIMIX 2106-16-LCD
- SONIMIX 2106-32-LCD
- SONIMIX 2106-64-LCD
- SONIMIX 2106-128-LCD
- SONIMIX 2106-256-LCD
- SONIMIX 2106-512-LCD
- SONIMIX 2106-1024-LCD
- SONIMIX 2106-10-LCD
- SONIMIX 2106-2x10-LCD
- SONIMIX 2106-3x10-LCD

With or without the NOX Converter Tester Option

- SONIMIX 2106-predivider-LCD

Table of Contents

FORWORD.....	- 5 -
INTRODUCTION	- 5 -
SPECIFICATIONS.....	- 6 -
The most common options.....	- 8 -
PRESENTATION OF THE DEVICE.....	- 9 -
Front view	- 9 -
Back view	- 10 -
Top view.....	- 12 -
Dimentions :	- 13 -
SCHEMES	- 14 -
Fluidics (only gas divider).....	- 15 -
Fluidics (only Nox converter tester)	- 16 -
Electronics	- 17 -
SONIMIX 2106-32 (gas divider only)	- 17 -
SONIMIX 2106-1024 (gas divider only)	- 18 -
Nox converter Tester	- 19 -
230V/ 110V Voltage Setting with PS 3550.....	- 19 -
230V/ 110V Voltage Setting with PS 4000.....	- 21 -
HOW TO START THE SONIMIX	- 22 -
Special case of a predivider	- 23 -
LCD INTERFACE / SOFTWARE	- 24 -
Overview of the Menus	- 24 -
Start Up	- 25 -
Main Menu.....	- 25 -
Operating Parameters Menu	- 27 -
Gas Maker sub-Menu :.....	- 28 -
Cylinder Maker sub-Menu :	- 28 -

Cylinder Plug-in sub-Menu :.....	- 29 -
Scenario maker sub-Menu	- 29 -
Mixture Generation Menu.....	- 30 -
Manual sub-Menu	- 31 -
Scenario sub-Menu	- 33 -
NOX converter tester sub-Menu.....	- 34 -
Zero Setting of the UV lamp	- 35 -
Configuration Menu	- 36 -
General Sub-menu	- 37 -
Set date and time sub menu	- 39 -
LNS intervention sub menu	- 40 -
Configuration sub menu	- 40 -
RS 232 sub menu	- 41 -
TCP/IP sub menu.....	- 41 -
The tools Menu	- 42 -
The history Sub-Menu	- 43 -
Test EV Sub-Menu.....	- 43 -
Test I2C Sub-Menu.....	- 44 -
Transfer Sub-Menu	- 44 -
MAINTENANCE.....	- 46 -
Software update.....	- 46 -
RECALIBRATION.....	- 46 -
TROUBLESHOOTING	- 47 -
REMOTE COMMAND.....	- 48 -
HyperText Transfer Protocol.....	- 48 -
AK protocol	- 48 -
Syntax	- 48 -
Error Handling.....	- 49 -
LIST OF THE AK INSTRUCTIONS	- 49 -
SRES	- 50 -
SREM.....	- 50 -
SMAN	- 50 -
STBY	- 50 -
ASTF	- 50 -
SLST.....	- 51 -
SSPL.....	- 51 -
SRUC (HCL).....	- 51 -
SVIO	- 52 -
AVIO	- 52 -
SVOU	- 52 -
AVOU	- 52 -

EFDA.....	- 53 -
AFDA	- 53 -
AGAT	- 53 -
EGAK	- 54 -
AGAK.....	- 54 -
ALST	- 54 -
AKAK	- 55 -
ASTZ	- 55 -
ADRU.....	- 55 -
AKEN	- 56 -
EKEN.....	- 56 -
APAR	- 56 -
ASYZ	- 57 -
ATEM.....	- 57 -
EGCF.....	- 57 -
AGCF	- 58 -
SKOP (NOX option)	- 58 -
SVSA (NOX option).....	- 58 -
SVSZ (NOX option)	- 59 -
SONO (NOX option)	- 59 -
SAIR (NOX option).....	- 59 -
SNOX (NOX option).....	- 59 -
ANOX (NOX option)	- 60 -

FORWORD

The SONIMX 2106-x-LCD represent a family of different models of Gas Dividers. The difference between the models are the numbers of dilution steps (from 16 to 1024 for the binary one and from 10 to 3x10 for the lin/log one) and the eventual built in Nox converter Tester option. This operating manual is valid for all models and will take care of all the options as compatibility with corrosive gases, additional inlets,... (even they are note installed in you specific device).

INTRODUCTION

The Gas Divider SONIMIX 2106-LCD is an easy to use programmable high precision mechanical binary reference gas mixer able to generate the " zero " and up to 1024 fixed steps of concentration with a **precision of the mixture better than 0.6% relative.**

Built in accordance with the ISO 6145/6 normalization, this instrument is equipped of pressure regulators and sonic nozzles. These components are essential and allow precision, stability, repeatability and homogeneity of the generated gas mixtures.

Due to its unique design, the Gas Divider generates a constant flow of mixture with following dilution points :

SONIMIX 2106-16-LCD	from 6% to 100% in 16 steps
SONIMIX 2106-32-LCD	from 3% to 100% in 32 steps
SONIMIX 2106-64-LCD	from 1.5% to 100% in 64 steps
SONIMIX 2106-128-LCD	from 1% to 100% in 128 steps
SONIMIX 2106-256-LCD	from 0.5% to 100% in 256 steps
SONIMIX 2106-512-LCD	from 0.2% to 100% in 512 steps
SONIMIX 2106-1024-LCD	from 0.1% to 100% in 1024 steps
SONIMIX 2106-10-LCD	from 10% to 100% in 10 steps
SONIMIX 2106-2x10-LCD	from 1% to 10% in 10 steps + from 10% to 100% in 10 steps
SONIMIX 2106-3x10-LCD	from 0.1% to 1% in 10 steps + from 1% to 10% in 10 steps + from 10% to 100% in 10 steps

The control of all command functions of the gas divider can be done through a touch screen LCD interface or through the RS 232 remote command. In remote mode, the standard communication protocol is in accordance with the "Arbeitskreis der Deutschen Automobil-Industrie" recommendations. In addition, the SONIMIX 2106 is equipped with an ETHERNET interface and with USB capabilities.

A flow-meter on the front face allows a constant visualization of the flow generated and can be selected manually by the end-user.

The major applications of the Gas Divider are:

- * calibration of analysers
- * verification of the analyser's linearity
- * simulation of special atmospheres
- * mixture generation for chemical pilot installations
- * ...

Gas Alimentation

<p>Diluted line</p>	<p>Pure or premixed dry gases such as CO, CO₂, NO, SO₂ Or low concentrated < 500 ppm corrosive gases : HCl, NH₃, H₂S, NO₂,...in AIR or N₂ If the compatibility of corrosive gases is installed, the concentration of the corrosive gas cylinders concentration can go up to 10%. In this case corrosive gases should be dry and purges should be done correctly.</p>
<p>Carrier Line</p>	<p>Dry AIR and N₂ from a cylinder or a LNS Zero Air Generator</p>
<p>Dilution Range</p>	
<p>Mono Range :</p>	<p>10 steps (SONIMIX 2106-10) (1 step every 10%) 16 steps (SONIMIX 2106-16) (1 step every 6.6%) 64 steps (SONIMIX 2106-64) (1 step every 0.5%) 128 steps (SONIMIX 2106-128) (1 step every 1%) 1024 steps (SONIMIX 2106-1024) (1 step every 0.1%)</p>
<p>Multi Range :</p>	<p>2 ranges of 10 points (0, 1%,2%,...10% + 10%, 20%,...100%) SONIMIX 2106-2x10 3 ranges of 10 points (0, 0.1%, 0.2%,...1% + 1%,2%,...10% + 10%, 20%,...100%) SONIMIX 2106-3x10</p>
<p>Total flow</p>	<p>2500 Nml/min of mixture as standard (N₂ equivalent) 5000 NmL/min as option, other flow upon request adjustable by the by-pass valve and visualised by the flow-meter</p>
<p>Accuracy of the concentration</p>	<p>Better than +/-0.5% relative</p>
<p>Repetability</p>	<p>Better than +/-0.2% relative</p>
<p>Influence of external parameters</p>	<p>effects of temperature changes from -5 to 35°C, and atmospheric pressure variations from 800 to 1200 mbar included in the repeatability.</p>
<p>Stabilisation time</p>	<p>< 20 seconds</p>
<p>Calibration</p>	<p>by volumetric means, traceable to most National Standards Possibility to have an ISO 17025 Calibration certificate</p>
<p>Inlet pressure</p>	<p>from 2.7 to 3.3 bar relative</p>
<p>Pressure of the mixture</p>	<p>vacuum to 1 bar rel</p>
<p>Alarms</p>	<p>Monitoring of the alimenting and mixture pressures</p>
<p>Setting and communication Modes</p>	<p>local or remote</p>
<p>* local with LCD display</p>	<p>LCD display with touch screen</p>
<p>* remote by standard interface</p>	<p>RS-232, 1200 to 9600 bauds, other parameters 100% adjustable standard communication protocol : AK ETHERNET USB</p>
<p>Voltage and Power consumption</p>	<p>50W 230VAC/50Hz or 60Hz ; 50W 117VAC/60Hz</p>
<p>Fittings</p>	<p>Swagelok 1/4" or 6mm, 316L < 10⁻⁷ mbar l/s,</p>
<p>Tightness</p>	<p>< 10⁻⁷, verified by He detection</p>

Casing and Net weight	19" 3HE/84 TE , 500mm deep / 10 to 20 Kg depending on model
Nox Converter Tester Option :	
Diluted Line	NO cylinder of 1000, 100 or 50 ppm (depending of the model) mixed with N2
Carrier Line	Air or Oxygen
Range	5 to 50 ppm NO2 or 25 to 100 ppm NO2 or 300 to 1000 ppm NO2
Total flow	2200 Nml/min
Dilution of the NO cylinder	90%
Communication Mode	RS 232 /Ethernet / LCD display (all common with the gas divider)
Inlet pressure	from 2.7 to 3.3 bar relative
Pressure of the mixture	vacuum to 1 bar rel
Additional weight	5 Kg
Casing	Integrated in the gas divider casing

THE MOST COMMON OPTIONS

The most common options are :

- Compatibility with corrosive gases
- 4 additional inlets (maximum 3 set per devices)
- RS 232 remote command
- NOx converter tester
- GasCal Software
- ISO 17025 Calibration certificate

(note the every device is delivered at least with a standard volumetric calibration)

PRESENTATION OF THE DEVICE

FRONT VIEW

The Front Panel consist of a touch screen LCD display and a flow meter.

The LCD display is used to enter all the requested parameter (type of gas, concentration of cylinder, ...) and to generate gases.

The flow meter is used to select flow rate at the outlet of the SONIMIX. The rest of the flow rate will go to the by-pass.

Gas Divider only

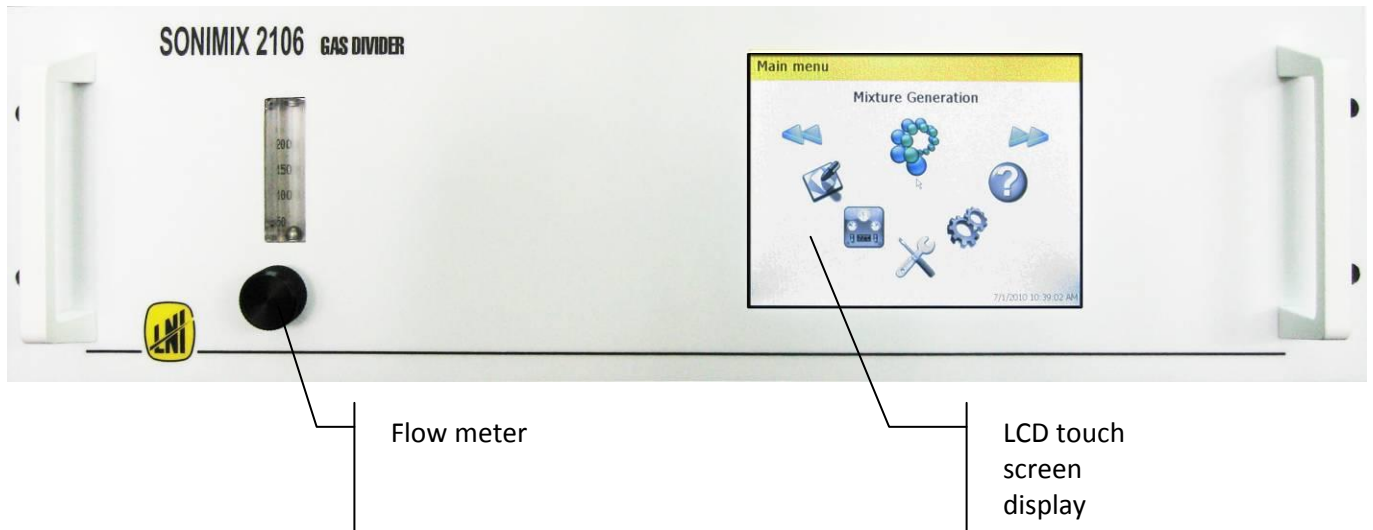

Gas Divider with Nox converter Tester option

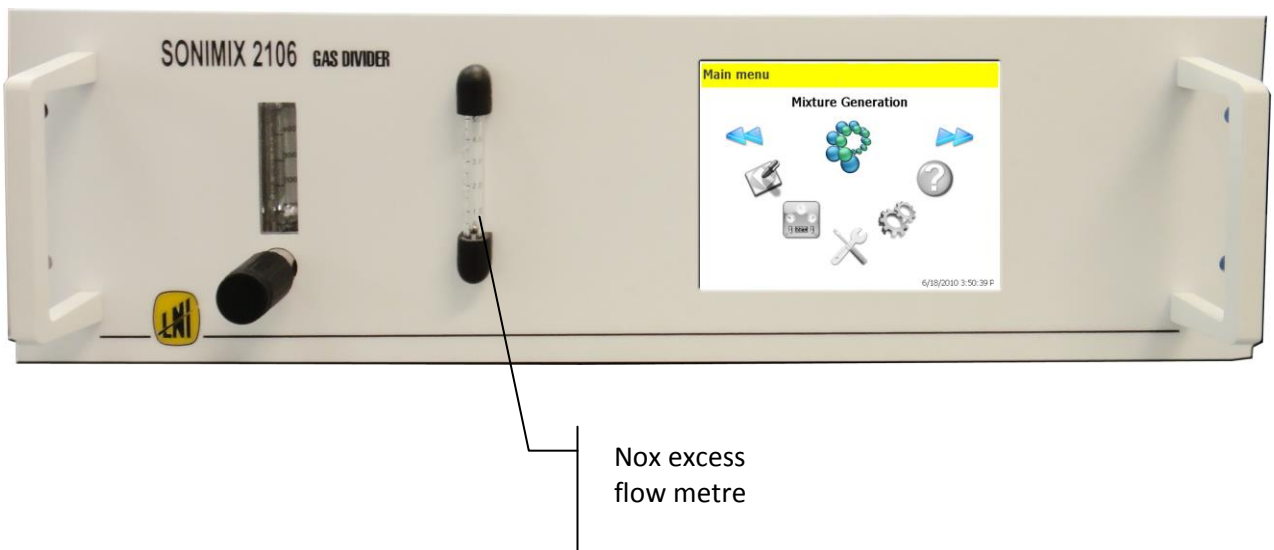

BACK VIEW

The back panel consist of the fluidics inlets and outlets, the communications connectors (Ethernet, USB and RS 232) and the power line. The first picture show the most simple device (no options)

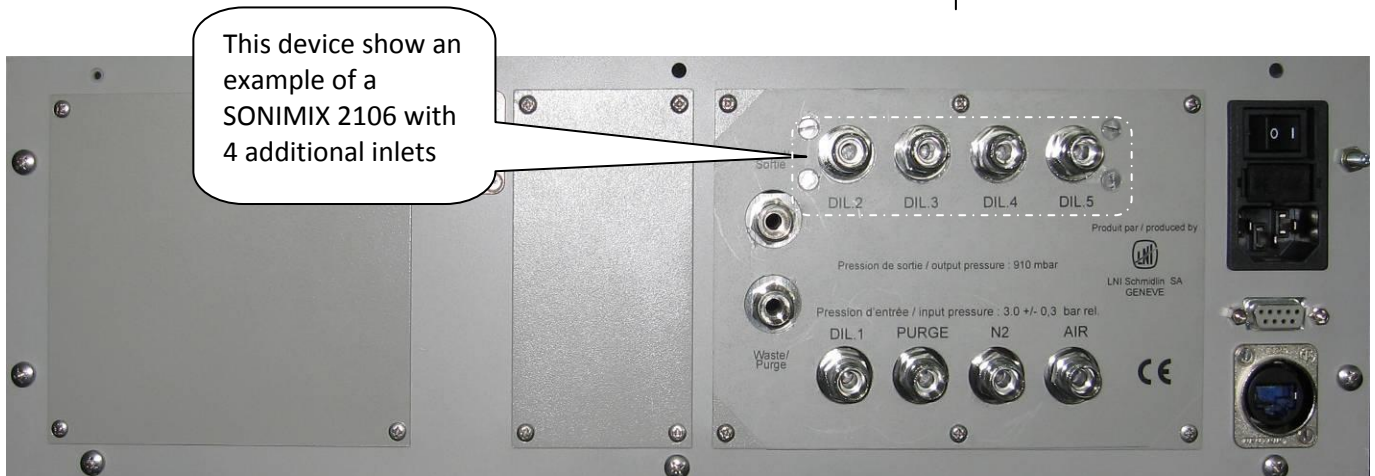
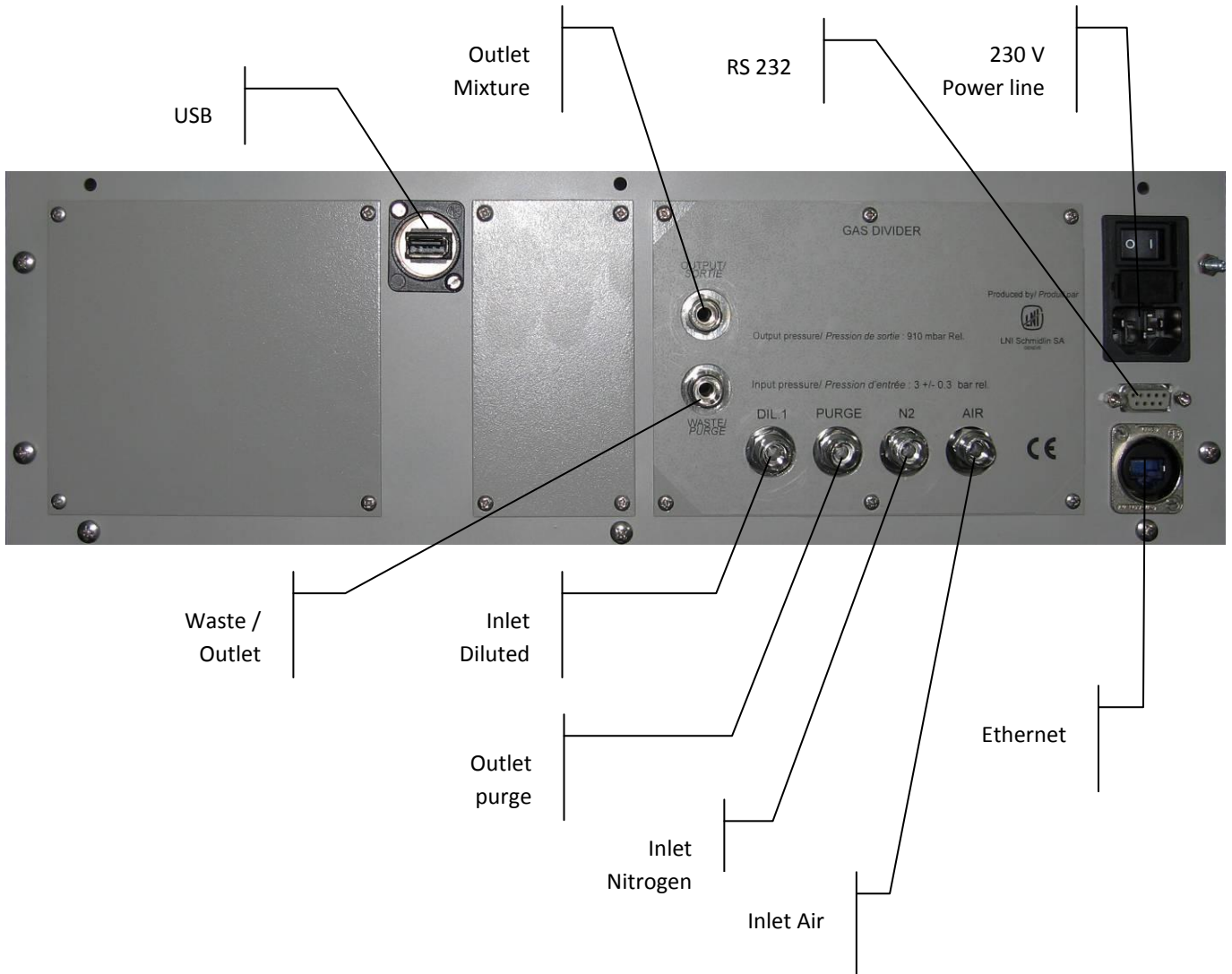

Back view with a model with NOX converter tester :

Nox converter
tester Inlets and
outlets

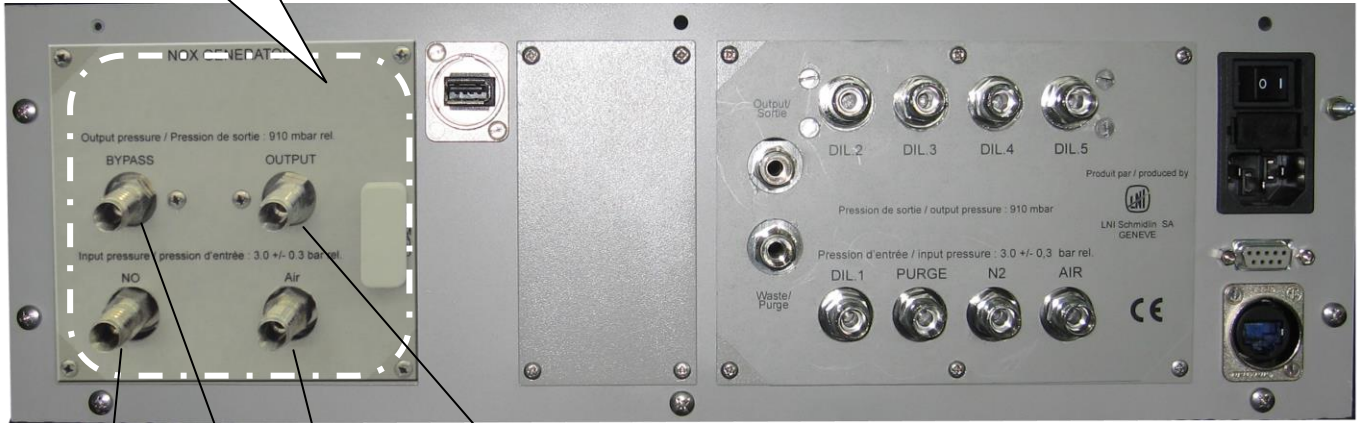

Inlet NO

Inlet Air

Outlet
purge

Outlet NO/Air or
NO₂Nitrogen

TOP VIEW

Top View of a SONIMIX 2106-32-LCD with 5 Sonic Nozzles

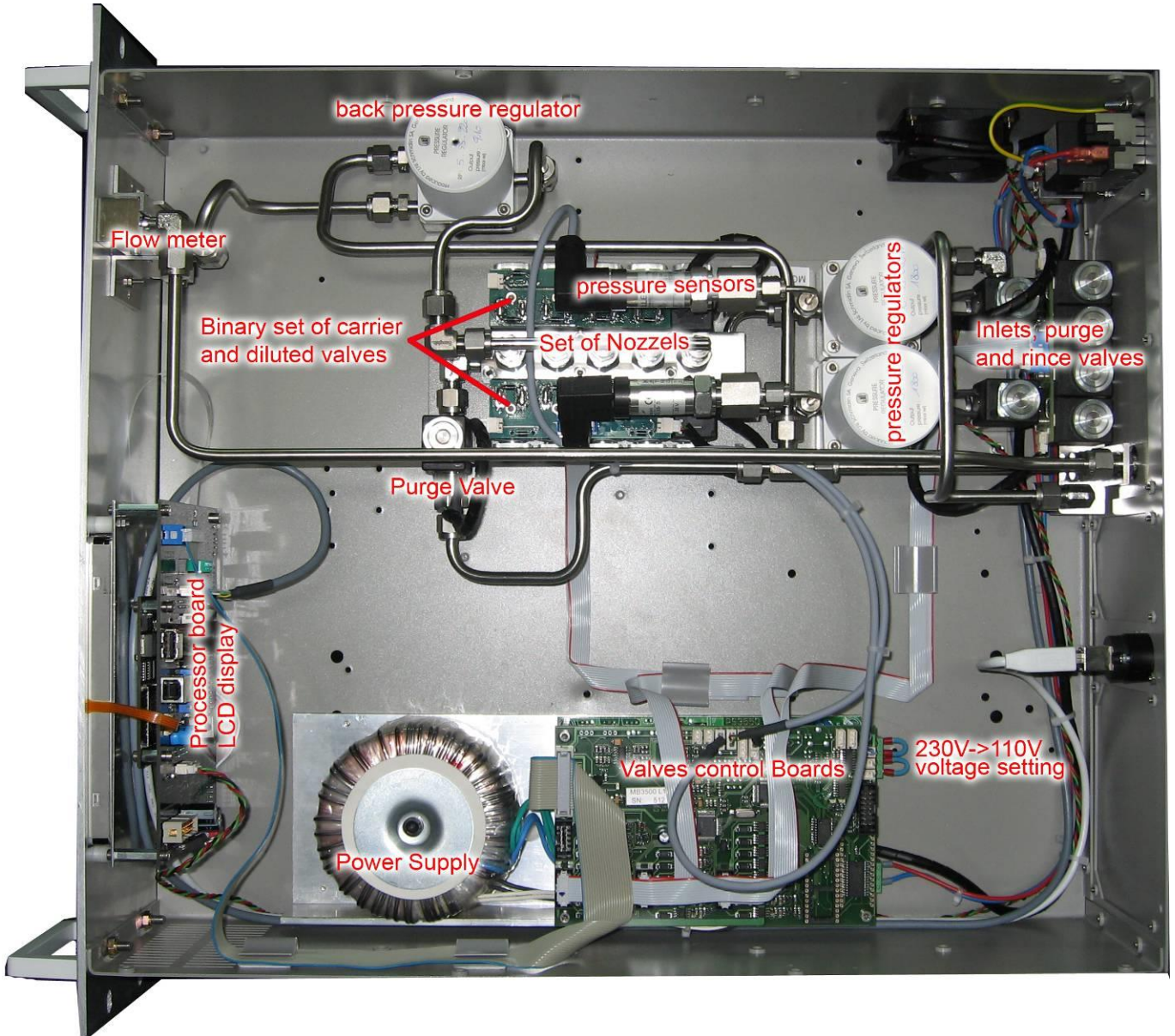

In this case, the model is the SONIMIX 2106-1024 (with 10 sonic Nozzles) and 4 additional inlets. The differences with the previous model are the number of nozzles, number of control board valves and the 4 additional inlets.

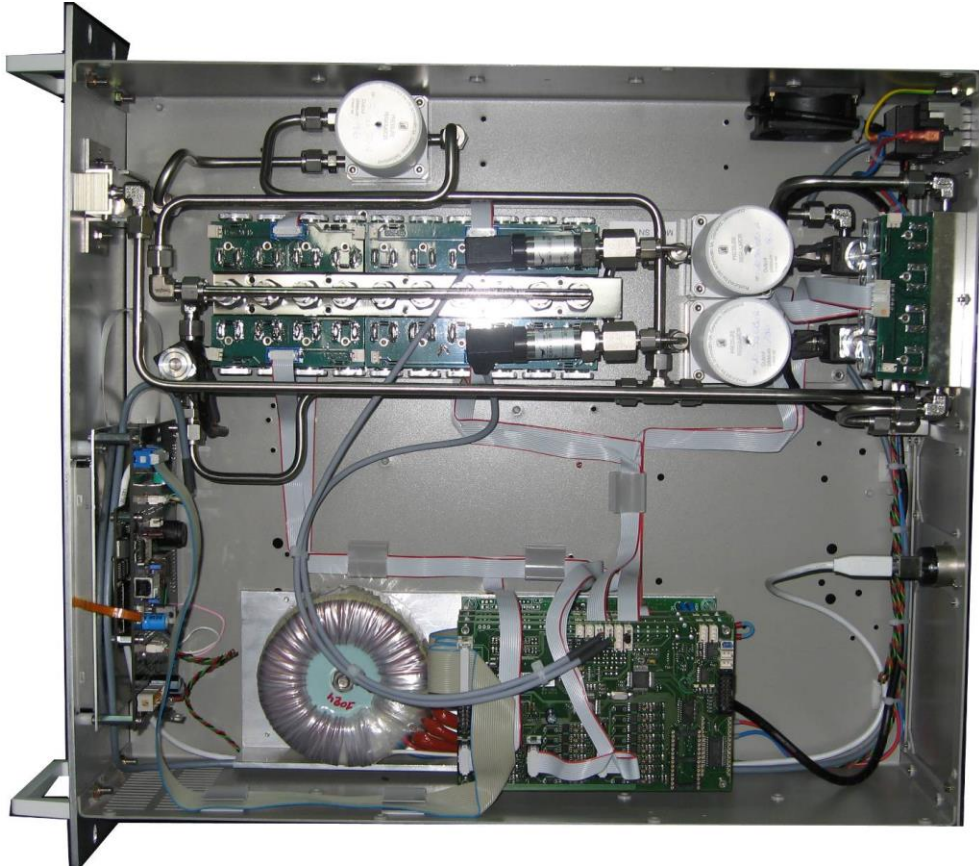

Top view including a NOx converter tester :

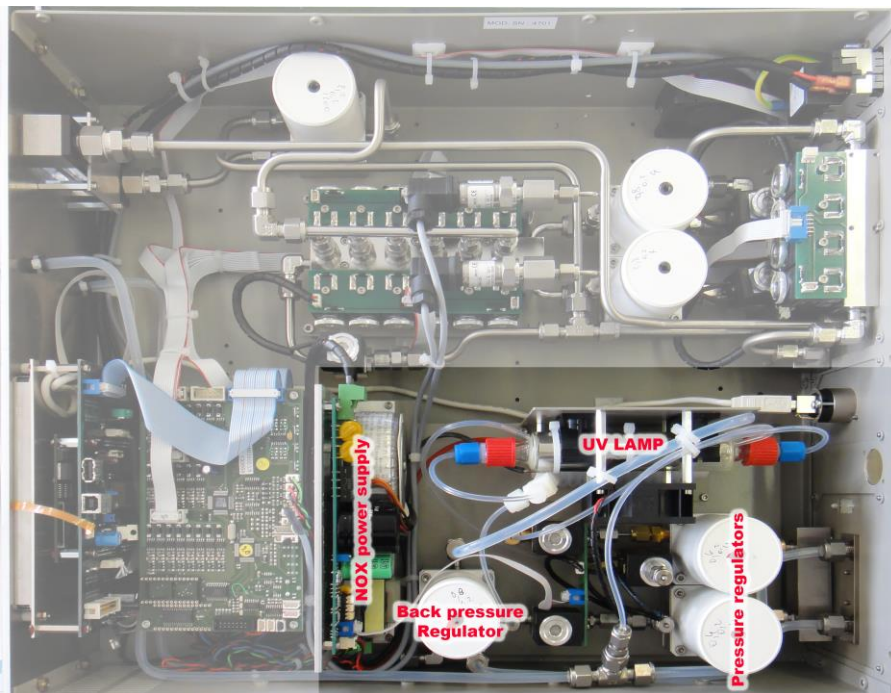

DIMENTIONS :

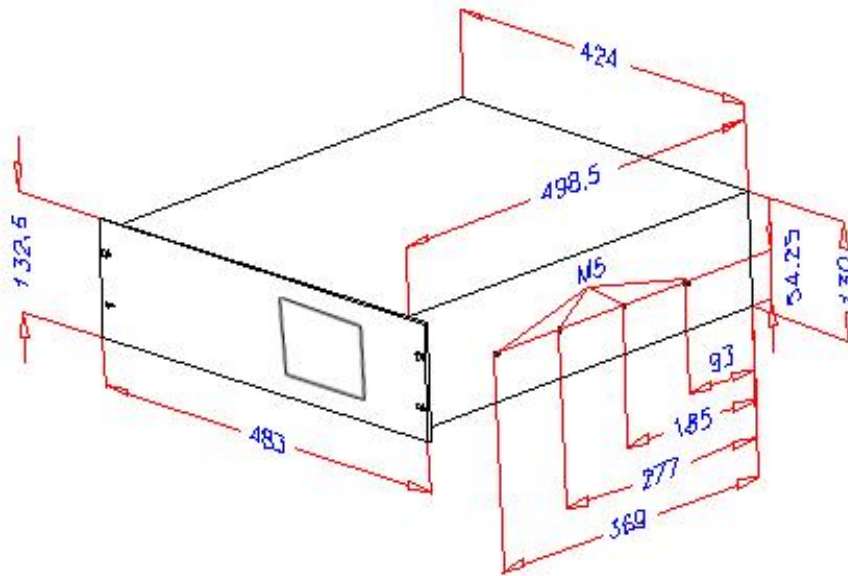

TRANSPORT AND STORAGE CONDITIONS

Temperature	Minimum -10°C , maximum $+45^{\circ}\text{C}$
Humidity	Inferior to 90%Rh, non condensing
Chocks and vibrations during transport	Chocks $< 1\text{g}$; vibrations $< 0.2\text{g} / 5\text{Hz}$
Instrument's position	Horizontal

The above mentioned values are considered for an instrument transported in its original new packing.

Recommendations for the transport

When the instrument is shipped back to the factory for recalibration or repair, the gas divider + Nox should be packed in its original packing with the inlets and outlets protected against any accidental penetration of dust or particles of the package.

FUNCTIONING CONDITIONS

Operating temperature	Minimum $+15^{\circ}\text{C}$, maximum $+40^{\circ}\text{C}$
Humidity	Inferior to 80%Rh, non condensing
Atmospheric pressure	From 850 to 1150 hP
External vibrations	Inferior to $0.05\text{g} / 25\text{Hz}$
Instrument's position	Horizontal

FLUIDICS (ONLY GAS DIVIDER)

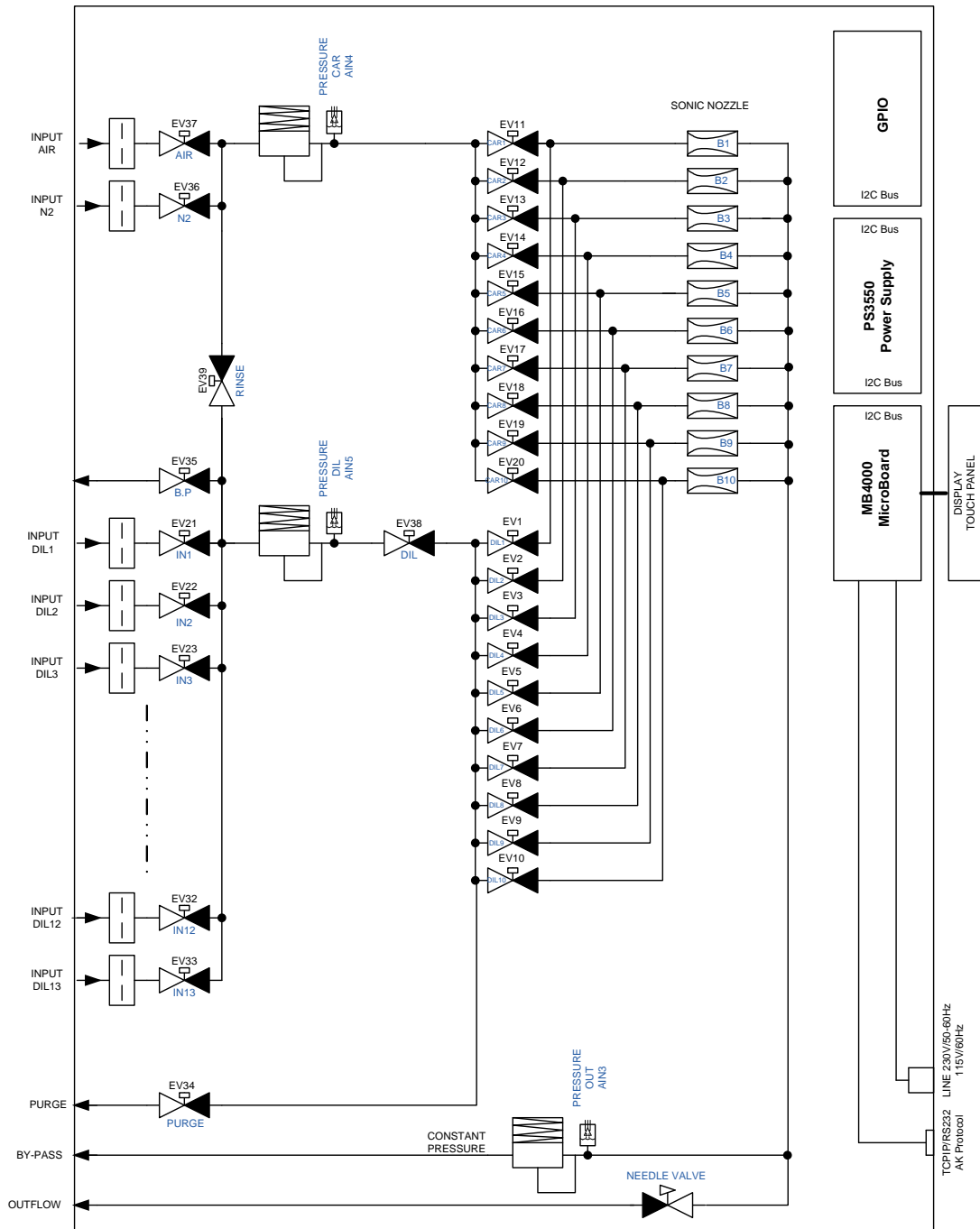

FLUIDICS (ONLY NOX CONVERTER TESTER)

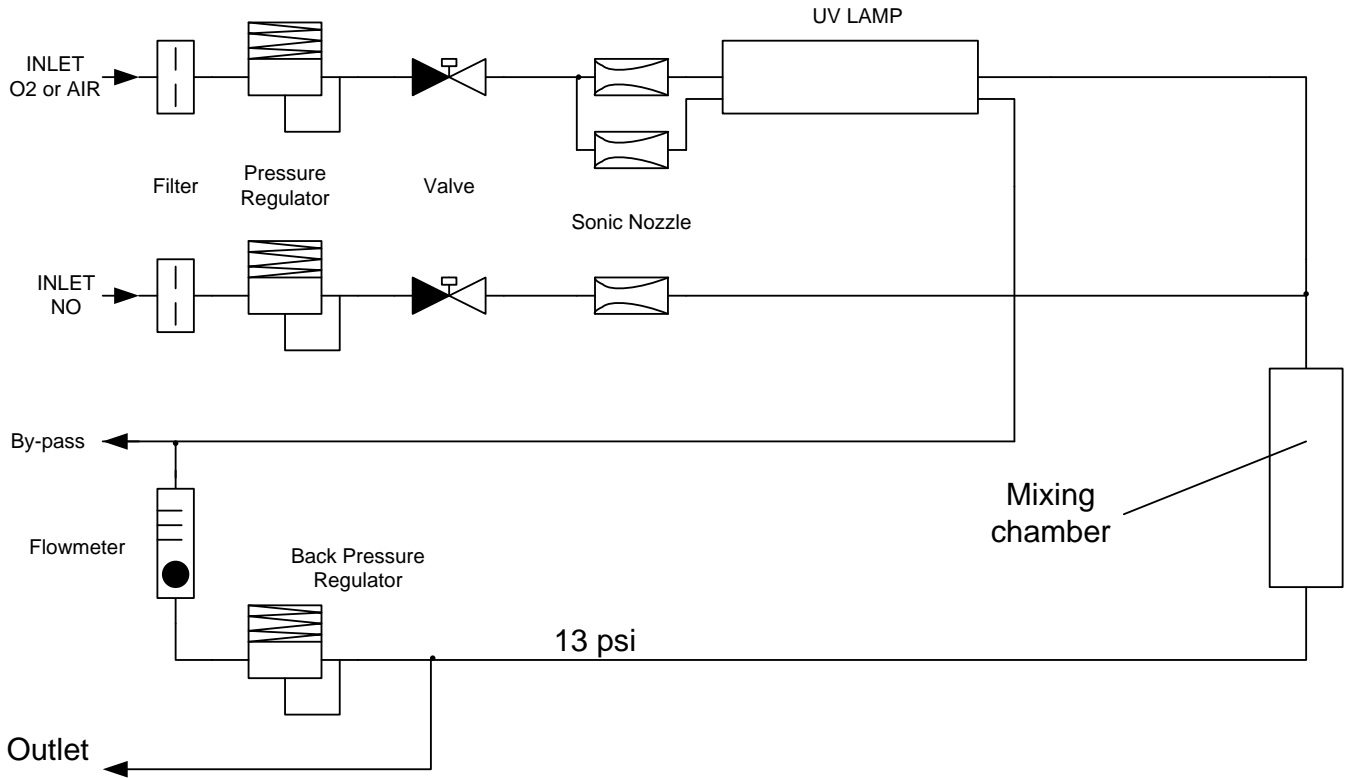

ELECTRONICS

SONIMIX 2106-32 (gas divider only)

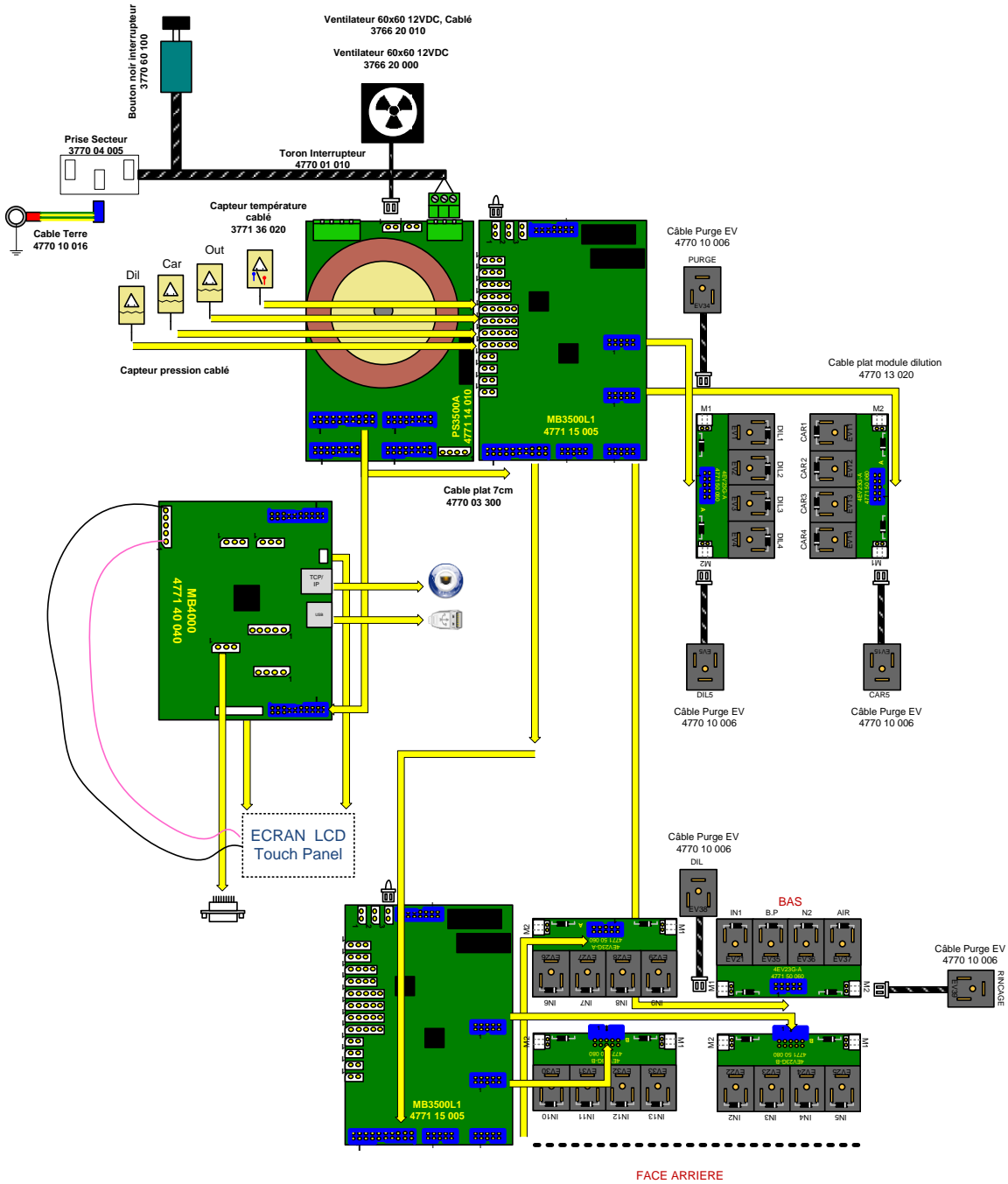

SONIMIX 2106-1024 (gas divider only)

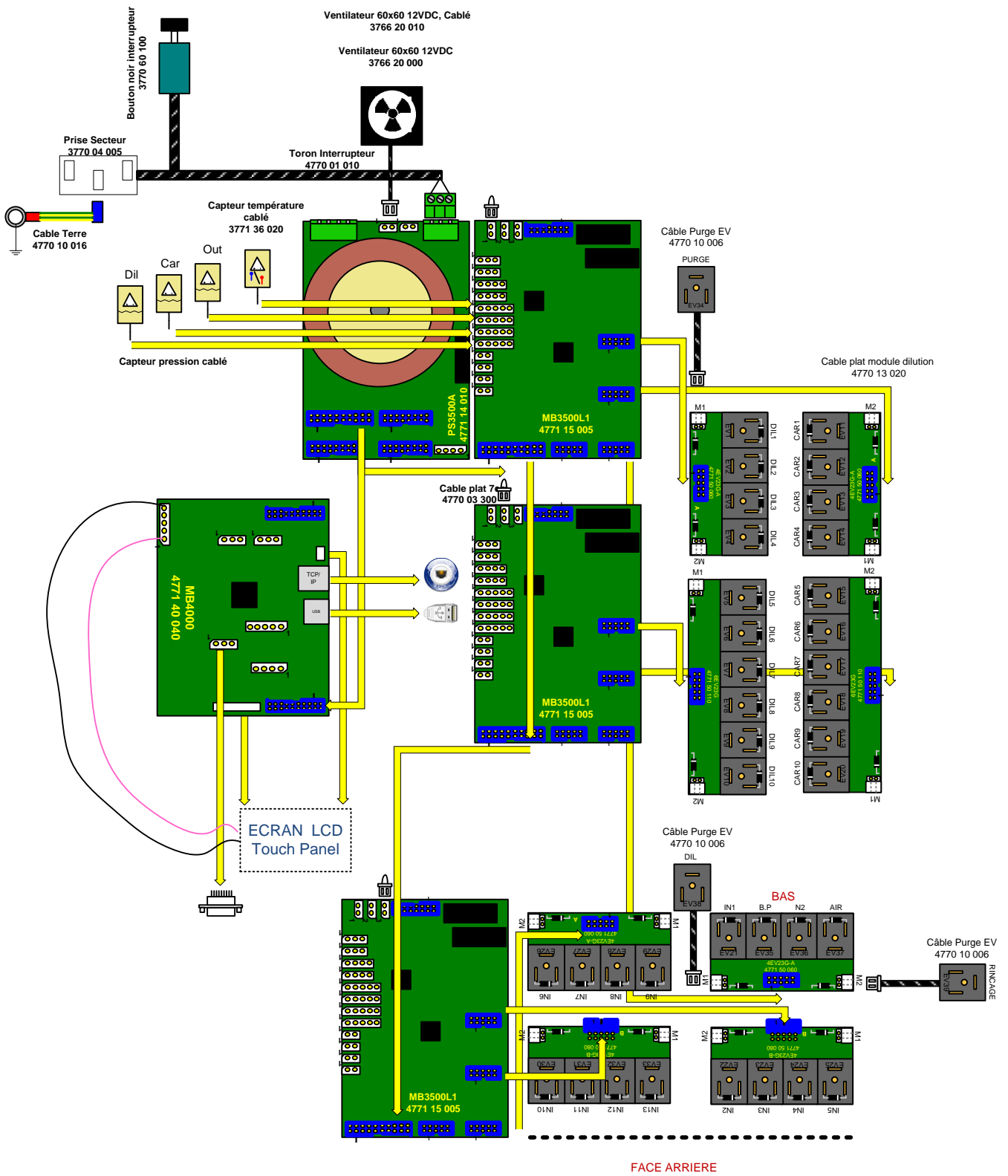

Nox converter Tester

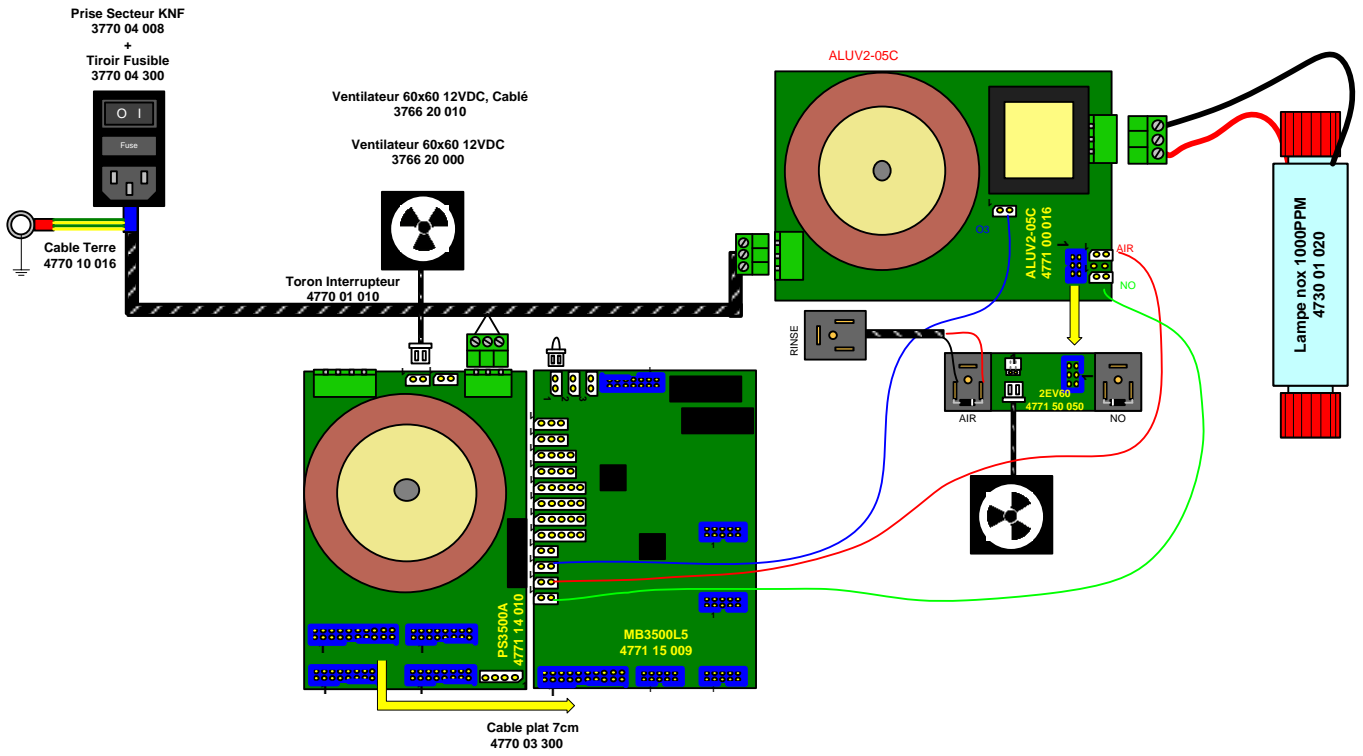

To use the SONIMIX device at another voltage setting than the one set at the factory, the following jumper should be set.

110 V
setting

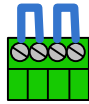

230V
setting

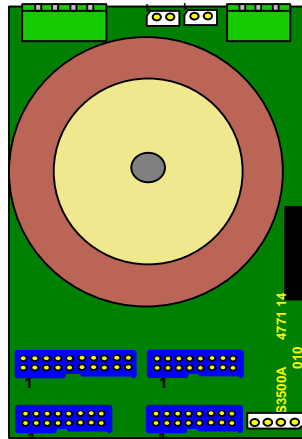
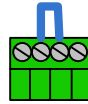

230V/ 110V VOLTAGE SETTING WITH PS 4000

To use the SONIMIX device at another voltage setting than the one set at the factory, the following jumper should be set.

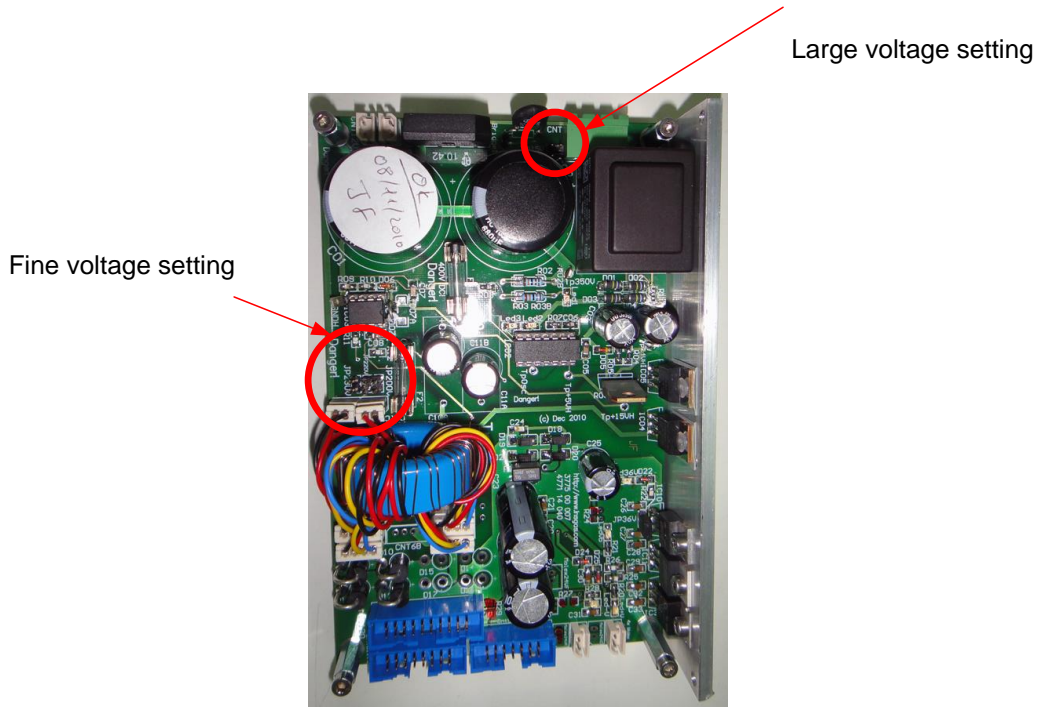

voltage	Fine voltage setting	Large voltage setting
100V		
110V		
220V		
230V-240V		

HOW TO START THE SONIMIX

Read carefully the Operating Manual
Connect the SONIMIX to the power line



Check if the setting voltage is correct (100V/110V or 230V)

Connect the SONIMIX to the gas Cylinders



ONLY USE ELECTROPOLISHED STAINLESS STEEL TUBES

Set the pressure regulator of the cylinders to 3 bar rel

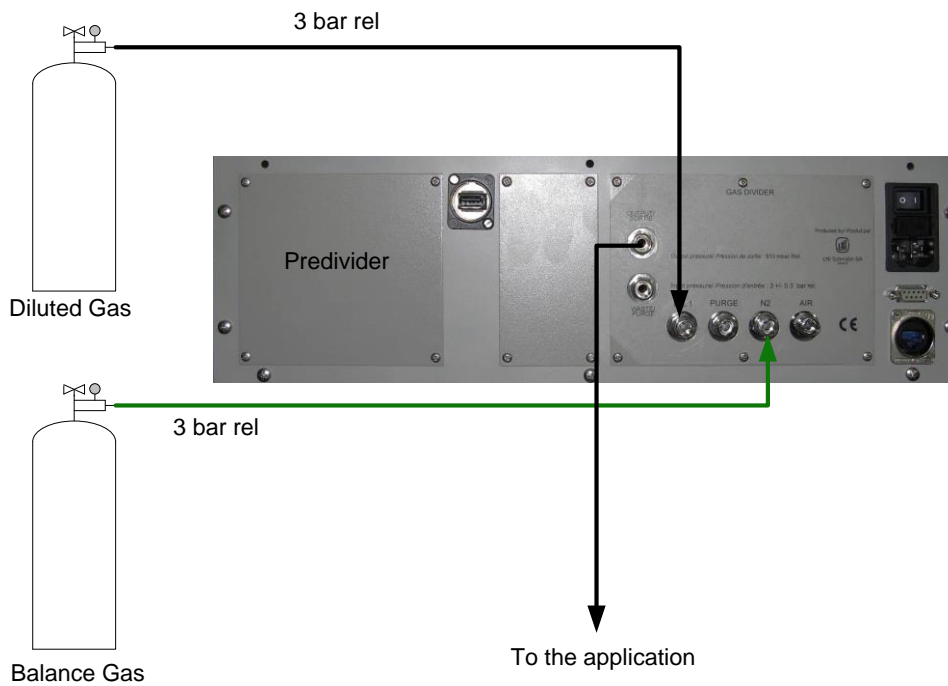

Set the operation parameter

Set the purge and rinse time (configuration\general)

Connect the outlet of the SONIMIX to your application

Connect the bypass of the SONIMIX to an exhaust

Generate dilution points

SPECIAL CASE OF A PREDIVIDER

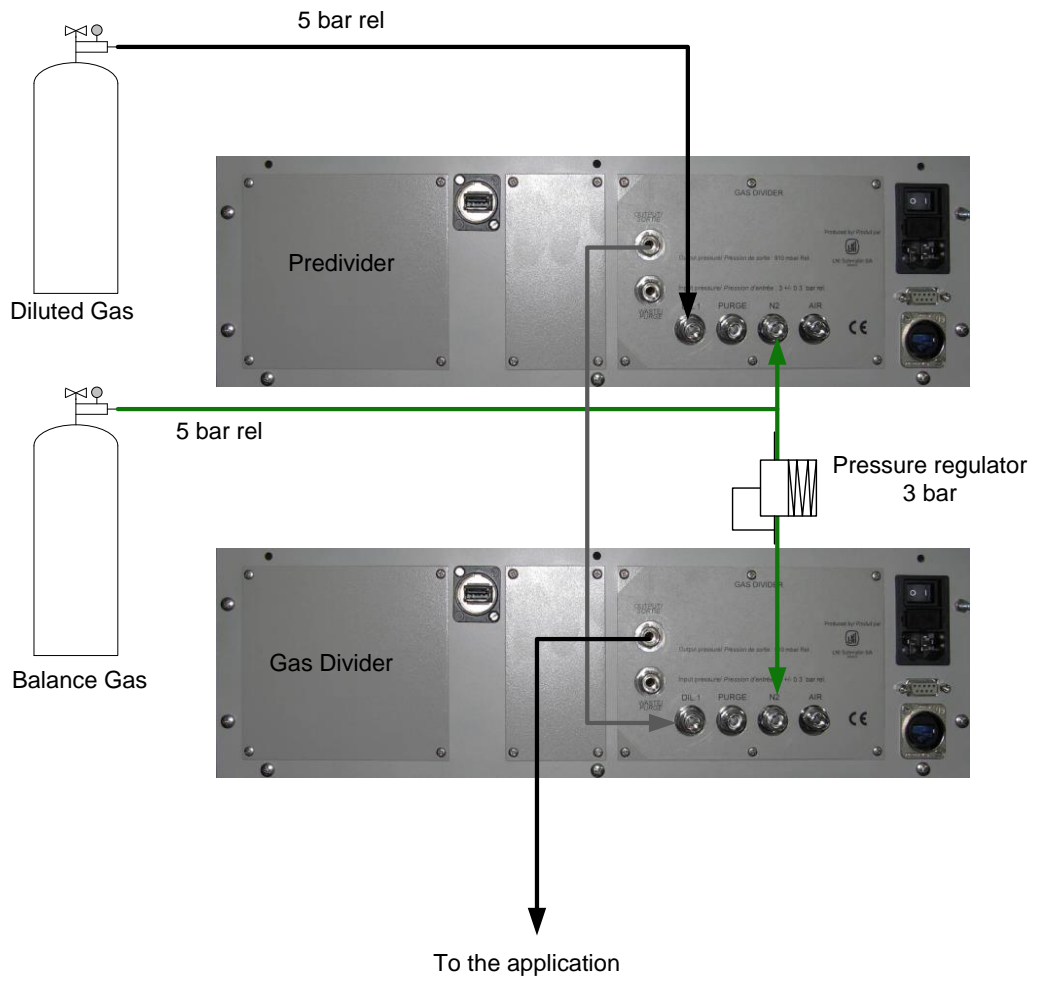

LCD INTERFACE / SOFTWARE

The SONIMIX has an user friendly LCD interface. The software consist in Menu and sub menus.

OVERVIEW OF THE MENUS

SONIMIX 2106
Gas Calibration System
Loading...

→

Main menu
Mixture Generation

The following image shows a grid of screenshots representing the software's menu structure:

- Génération mélange**: Main menu for mixture generation.
- NOx**: NOx calibration screen with a progress bar and a value of 90.909.
- Operating parameter**: Selection screen for Scenario maker, Cylinder plug in, Cylinder maker, and Gas maker.
- Configuration**: General, Date and Time, and I2C settings.
- Tools**: History, EV Test, Test I2C, and Transfer options.
- Board panel**: Visual representation of the hardware board.
- Mode Managet**: Stand-by and Mixture control screen.
- Scenario Mode**: Table for defining scenarios with columns for Function, CO, O2, and Duration.
- Gas maker**: Input fields for Selection, Bottle, Formula, Molecular Weight, Specific heat at cut pressure, Specific heat at cut volume, Density, and Coef. Gas Conversion Gas / N2.
- Set date and time**: Calendar and time selection screen.
- Test EV**: EV test configuration screen.
- Set Mixture**: CAR Input and Component selection screen.
- Scenario Mode**: Automatic mode selection screen.
- Cylinder maker**: Selection and input fields for bottles.
- General**: Alarms, Language, Backlight, History, Pressure Unit, and Temperature Unit settings.
- Test I2C**: I2C test configuration screen.
- Scenario maker**: Detailed scenario configuration screen.
- Cylinder plug in**: Bottle selection and input fields.
- RS232**: Baud Rate, Data Bits, Stop Bits, Parity, and Flow Control settings.
- Transfer**: Options for To USB Drive and From USB Drive.
- Composition of mixture**: Table for defining mixture components.
- Scenario maker**: Another instance of the scenario configuration screen.
- TCP/IP**: IP Address, Subnet Mask, and Default Gateway settings.
- History**: Log of operations.
- SX2106 Configuration**: Name, Serial number, Model, Ports, Baud, I2C, Production date, and Software version.
- LWI - Schmälin SA Intervention**: Unlocking code screen with a numeric keypad.
- Factory settings**: Factory reset and configuration screen for various parameters like Flow, Pressure, Flow Limit, etc.

START UP

Once you turn ON the SONIMIX, 3 beeps will be emitted by the device.
Just after, following screen will appear :

SONIMIX 2106

Gas Calibration System



Loading...



The innovative  swiss made products

Version : 1.20

The program is charging the different windows. Once finished the main menu will appear.

MAIN MENU

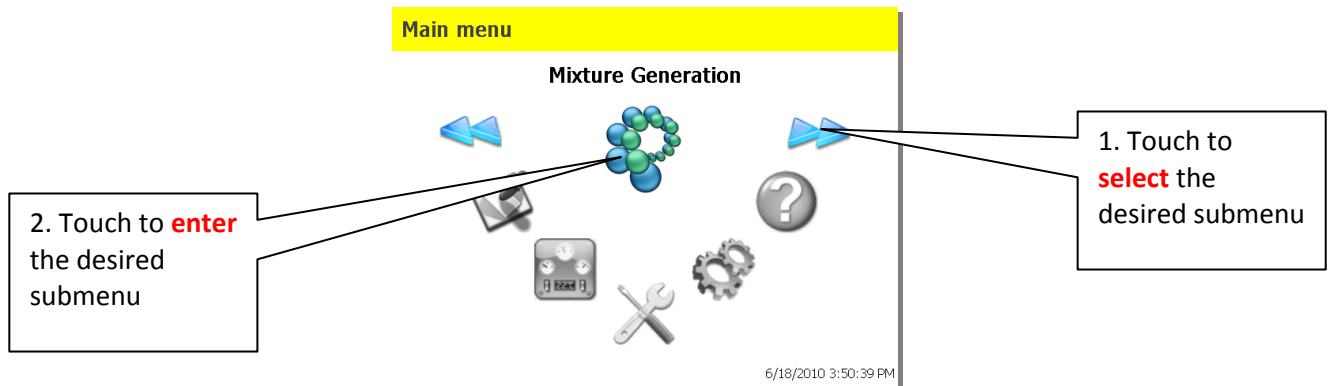

The main menu gives access to the following sub menus :

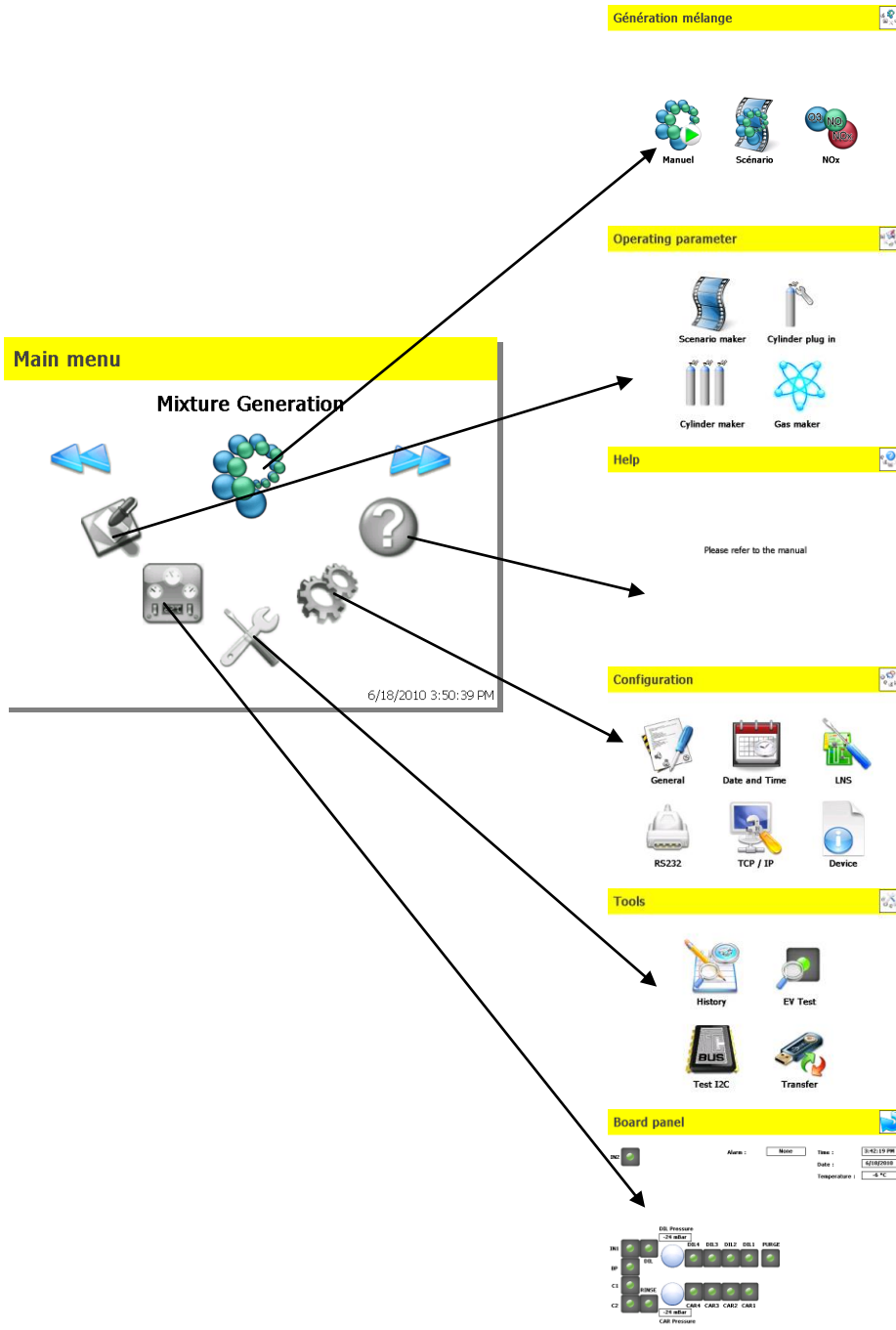

To generate concentration manually or using the Scenario

To set the cylinders values, gases and program a scenario

help

To configures the parameters linked to the device (remote command) or general parameters like date, time,...

Some tools to open valves, read and transfer the history to USB or test the remote command.

To see which valve is open or closed. This menu is also accessible from other menus.

OPERATING PARAMETERS MENU

Operating parameter

Touch to **enter** the desired submenu

Press this icon to get back to the previous menu

Operating parameter

Scenario maker

Cylinder plug in

Cylinder maker

Gas maker

To create new gases (if they are not in the predefined list)

To create a gas cylinder

To "connect" a cylinder to the SONIMIX

To program a scenario (for automatic linearity or repeatability)

Scenario maker

07 Active Function: Mixture CAR Input DIL. Input Duration: 7 min.

Composition of mixture
Component: CO
Concentration:
Point (1/25)
Real Conc.: 0.006
Unit: %

Cylinder plug in

Bottle	Air	
1		0.000 ppbv
2		0.000 ppbv
3		0.000 ppbv
4		0.000 ppbv
5		0.000 ppbv
Balance	AIR	1000000000.000 ppbv

Carrier

Gas maker

Selection: AIR
Formula: AIR
Molecular Weight: 28.95 (g/mol)
Specific heat at cst pressure: 0.2418 (kcal/kgK)
Specific heat at cst volume: 0.1724 (kcal/kgK)
Density: 1.361 (kg/m3)
Coef. Gas Conversion Gas / N2: 1.018

Cylinder maker

Selection	Air	
Bottle	Air	
1		0.000 ppbv
2		0.000 ppbv
3		0.000 ppbv
4		0.000 ppbv
5		0.000 ppbv
Balance	AIR	1000000000.000 ppbv

Gas Maker sub-Menu :

If the gas you intend to mix is not in the list, you can add it to the list. To do so, you have to find out following parameters : Molecular weight, specific heat at constant pressure and volume (at the same temperature) and the density. The software will then calculate the coefficient factor that will be used in the dilution ration calculations.

Gas maker

Selection	AIR
Formula	AIR
Molecular Weight	28.95 [g/mol]
Specific heat at cst pressure	0.2418 [kcal/kgK]
Specific heat at cst volume	0.1724 [kcal/kgK]
Density	1.161 [kg/m ³]
Coef. Gas Conversion Gas / N ₂	1.018

Parameters to be entered to set a new gas

Touch this icon to select a gas

Touch this icon to delete a gas



If you modify the parameter of an existing gas, this will change the coefficient gas converter factor. As consequence, the dilution ratio of the modified gas will not be right anymore.

Cylinder Maker sub-Menu :

With this menu, you can create different type of cylinder (representing the one you have in your lab and that you will attach to the SONIMIX). You can have in your cylinder up to 5 different components plus 1 balance gas.

Cylinder maker

1. Enter a new name for your cylinder

2. Select a gaz (if the gas do not exist, refer to previous chapter **Gas Maker sub-Menu**)

3. Enter the concentration of the gas

4. Touch this icon to choose a unit (ppb, ppm, %)

5. Choose your balance gas

Touch this icon to delete a cylinder

Selection	Air
Bottle	Air
1	0.000 [ppbv]
2	0.000 [ppbv]
3	0.000 [ppbv]
4	0.000 [ppbv]
5	0.000 [ppbv]
balance	AIR 1000000000.000 [ppbv]

If you cylinder has 100% concentration, enter it as Balance gas only.

Cylinder Plug-in sub-Menu :

This menu is used to teach the software, which gas cylinder is physically attached to the SONIMIX. The software automatically recognize the number of inlet (the minimal configuration is 2 inlet for the carrier (normally Air or N2) and 1 for diluted. Then for each option of additional inlets there will be 4 diluted more.

Cylinder plug in

1. Press the cylinder to change the physical channel of the carrier gas. By default Nitrogen is N° 1 and Air is N°2

2. Select your cylinder. If the cylinder do not exist, refer to previous chapter **Cylinder Maker sub-Menu**

Bottle	Value	Unit
1	0.000	ppbv
2	0.000	ppbv
3	0.000	ppbv
4	0.000	ppbv
5	0.000	ppbv
Balance	AIR 1000000000.000	ppbv

Carrier

Diluted

Do the same with the Diluted cylinder

Scenario maker sub-Menu

The scenario maker able to perform automatically 10 different dilutions steps. This is ideal to perform linearity tests or repeatability tests. The parameter to set are the cylinders that will be used, the time duration of the point, the trace gas (this is necessary for multiple component cylinder), the requested concentration of the traced component and the unit.

Scenario maker

1. Use this icon to activate the point (a non activated point will not be generated)

2. Select what the point should do : « stand-by, mixture or purge »

3. Select the carrier and diluted gas. If you do not find the right cylinder, refer to previous chapter **Cylinder Plug-in sub-Menu**

4. Set the time during which the point should be generated

5. Press this icône to go to the **previous** point

6. Press this icône to go to the **next** point

7. Press this icône to go to the **previous** point

8. Press this icône to go to the **next** point

Composition of mixture

Component: CO

Concentration: []

Point (1/16): [-] 1 [+]

Real Conc.: 0.008

Unit: []

Duration: 7 min. [<] [>]

6. Select the gas you want to trace. In a multiple component gas cylinder all the component will be diluted with the same dilution ratio. This mean that only 1 component need to be set.

7. Set the concentration you would like to get. The software will automatically choose the closed corresponding dilution point

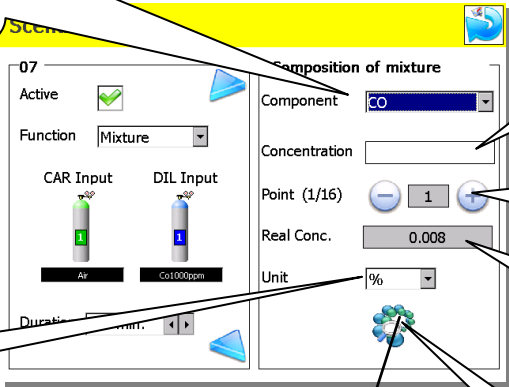

Or you can directly choose the dilution point.

5. To set the unit of the different concentrations.

Display of the effective concentration of the trace gas

Press this icon to view all the concentration of all your gases (if you have multiple component cylinders)

Composition of mixture

Component	Concentration	Unit
1 AIR	91.516	%
2 CO	0.008	%
3 N2	8.476	%

Once all parameters have been filled in, the gas divider SONIMIX 2106 can start to generate different gas mixtures.

The menu makes possible the generation of dilution points. Two different way are possible :

1. Generation fully manual
2. Automatic generation through the scenario.

Génération mélange

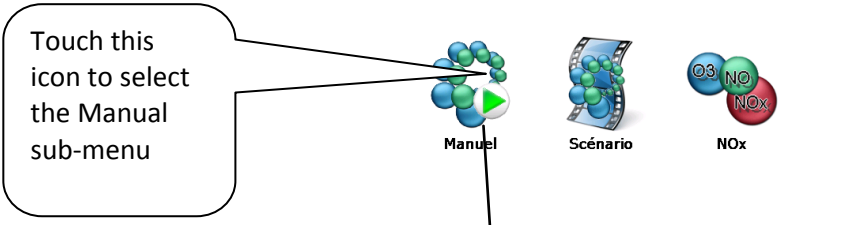

Touch this icon to select the Manual sub-menu

Manual sub-Menu

Mode Manuel

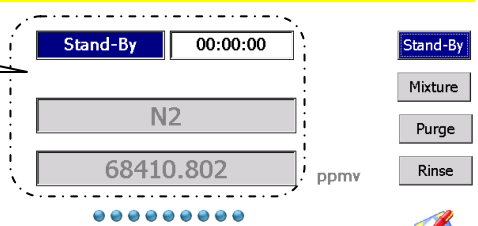

Information about what the SONIMIX is doing

Button to select the different actions : purge, rinse, stand-by and mixture

Press this icon to set or change the concentration.

Set Mixture

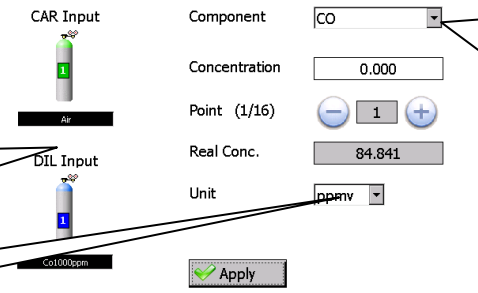

1. Select the carrier and diluted gas. If you do not find the right cylinder, refer to chapter **Cylinder Plua-in sub-Menu**

3. To set the unit of the different concentrations.

2. Select the gas you want to trace. In a multiple component gas cylinder all the component will be diluted with the same dilution ratio. This mean that only 1 component need to be set.

4. Set the concentration you would like to get. The software will automatically choose the closed corresponding dilution point

Set Mixture

Or you can directly choose the dilution point.

Display of the effective concentration of the trace gas

5. Validate once finished

Mode Manuel

Press this icon to view all the concentration of all your gases (if you have multiple component cylinders)

In this menu you will find which valve is open or closed, the pressure values, if there are alarms,...

Composition of mixture

Component	Concentration	Unit
1 AIR	91.516	%
2 CO	0.008	%
3 N2	8.476	%

Board panel

Pressure regulator and it's pressure value.

Valve (green light if the valve is open)

Scenario sub-Menu

Génération mélange

Manuel Scenario NOx

Touch this icon to select the Scenario sub-menu

This table show the 10 different dilution points, diluted and carrier cylinder Nr as well as the time duration of each point.

Scenario Mode

N°	Function	->DIL	->CAR	Duration [h:m:s]
1	Mixture	1	1	00:01:00
2	Stand-By			00:02:00
3	Purge	1	1	00:00:02
4	Stand-By			00:04:00
5	Mixture	1	1	00:05:00
6	Mixture	1	1	00:06:00
7	Mixture	1	1	00:07:00
8				
9				
10				

Press this icon to have more details about the set dilution points or modify them.

Press this icon to open the « start » scenario

In this menu you will find which valve is open or closed, the pressure values, if there are alarms,...

To stop the Scenario process.

Scenario Mode

Automatic

Date and time of start
06/18/2010 - 03:47:57 PM

Loop [h]
2

Start

Cancel

Set the start date and time

Set how many time do you want to wait until the scenario will repeat

Select this item if you want to repeat the scenario (until manual stop)

Start the scenario or cancel button

NOX converter tester sub-Menu

This menu is available only if the NOX converter tester option is installed.

Génération mélange

Manuel Scénario **NOx**

Touch this icon to select the Nox converter tester sub-menu

Select the NO gas cylinder attached to the NOX converter tester.

NOx

Stand-By
Zero
NO
NOx

Button to select the different actions :
Zero (Air)
NO
NO+O3->NO2

Button to select the quantity of Ozone (ie the quantity of NO2)

NOx 00:00:13
90.909 Unité ppmv
100.000 ppm

O3 41%
0%

The Nox converter tester menu is also available from the Gas Divider Generation Menu :

Mode Manuel

Stand-By 00:00:00
N2 68410.802 ppmv

Stand-By
Mixture
Purge
Rinse

NOx

Stand-By
Zero
NO
NOx

NOx 00:00:13
90.909 Unité ppmv
100.000 ppm

O3 41%
0%

Touch this icon to select the Nox converter tester sub-menu

Zero Setting of the UV lamp

If the UV lamp do not start at a few %, it is necessary to re-set the Zero value of the UV Lamp.
To do that, go to the "CONFIG SX 2106 Menu"



Press the « lock » icon and enter the « 1219 » as password.

Then the Nox converter tester window will look as follow :

2. Increase the O3 value until the UV lamp starts

1. Press the button to re-set the Zero of the UV lamp

CONFIGURATION MENU

This menu is used to set some general parameter and access (reading only) some feature of the SONIMIX gas divider.

The Configuration Menu is divided into several sections:

- General:** Alarms (ON), Purge [1] (1 s), Languages (English), Purge [2] (1 s), Backlight (ON), Rinse [1] (1 s), History (OFF), Rinse [2] (1 s), Pressure Unit (mBar), Temperature Unit (°C).
- Set date and time:** Calendar for June 2010, Time (09:09 PM).
- LNI - Schmidlin SA Intervention:** Unlocking code keypad.
- SX2106 Configuration:** Name (SX2106), Serial number (3039), Model (Standard), Point (16), Input (2), NOX (OFF), Production date (12/3/2009), Software version (1.00).
- TCP/IP:** Use DHCP (checked), IP Address (192.168.200.106), Subnet Mask (255.255.255.0), Default Gateway (192.168.200.1). Includes a Test button.
- RS232:** Baud Rate (9600), Data Bits (8), Stop Bit (1), Parity (None). Includes a Test button.

Used to choose different General setting

Use to set the day and time

Use to access the different internal values of the SONIMIX

Use to set the RS 232 parameters and test them

Use to set the TCP/IP parameters and test them

Access to the configuration of the SONIMIX

General Sub-menu

The first topic of this sub menu is to set the general parameters as Alarms (ON/OFF), language (French, German or English), the back light (ON/OFF), the pressure units (bar/PSI) and the temperature units (°C/°F).

The history memorize the different status of the gas divider. We recommend to set it ON, as it can be an important tool for our service department

Channel Number used for the RS 232 AK protocol

The purge and rinse values are very important parameter. Read carefully the following explanation about them

The purge 1 is used to clean the line between the Gas Cylinder and the inlets of the SONIMIX. This purge will remove all the air and humidity being in the line and replace it with the pure gas of the cylinder. This purge one should be done each time you replace the cylinder by another one or open the line for any reason. The purge will protect your gas divider if you use corrosive gases (do not use corrosive gases if the option : compatibility with corrosive gases has not been purchases). In addition, the purge will speed up the stabilization time of the mixture, as the line will be ready with the right gas.

Purge 1

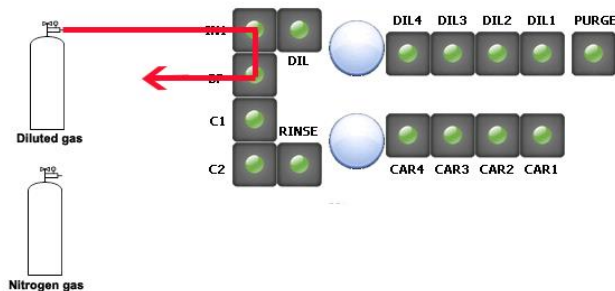

The purge 2 : Once the purge 1 is performed, the purge 2 will bring the new gas in the heart of the Mixing module of the SONIMIX. The purge 2 should be performed each time you change of inlet (with the basic model,

you only have 1 inlet. This mean each time you change the cylinder purge 1 and 2 should be performed). If you have purchased the option “additional diluted inlets”, you have the possibility to switch form one cylinder to another.

In this case, perform the purge 1 once you connect the cylinder and then only perform the purge 2 each time you switch form one cylinder to the other. (note that a Zero Nitrogen is performed during the purge process)

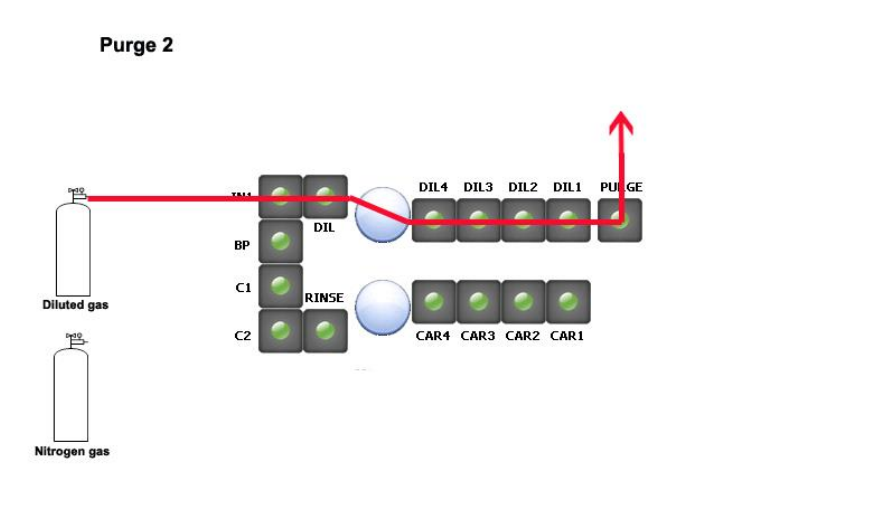

The rinse functions are used to clean with Nitrogen your instrument, once you have used corrosive gases or once you have finished to work with the SONIMIX dilution system. The same process apply for the rinse function as for the purge function.

The rinse 1 will clean with nitrogen the inlets of the SONIMIX

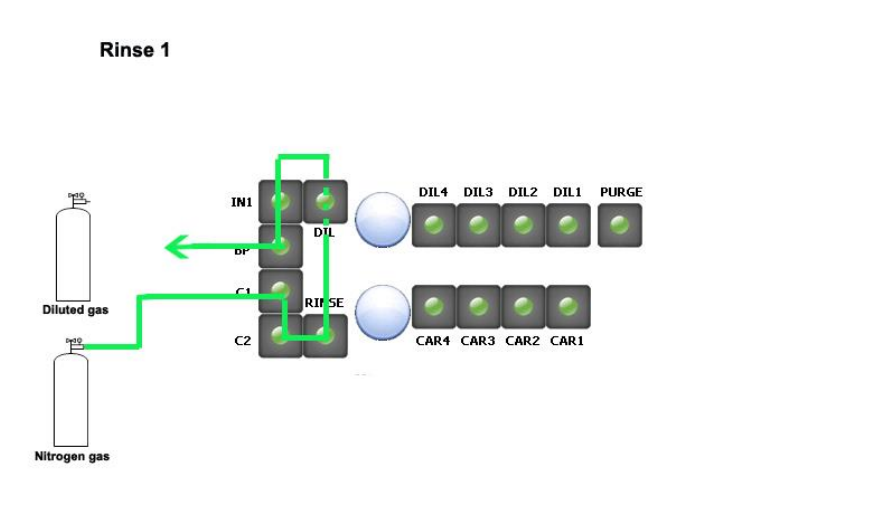

the rinse 2 : will clean with Nitrogen the heart of the dilution system, including the outlet.

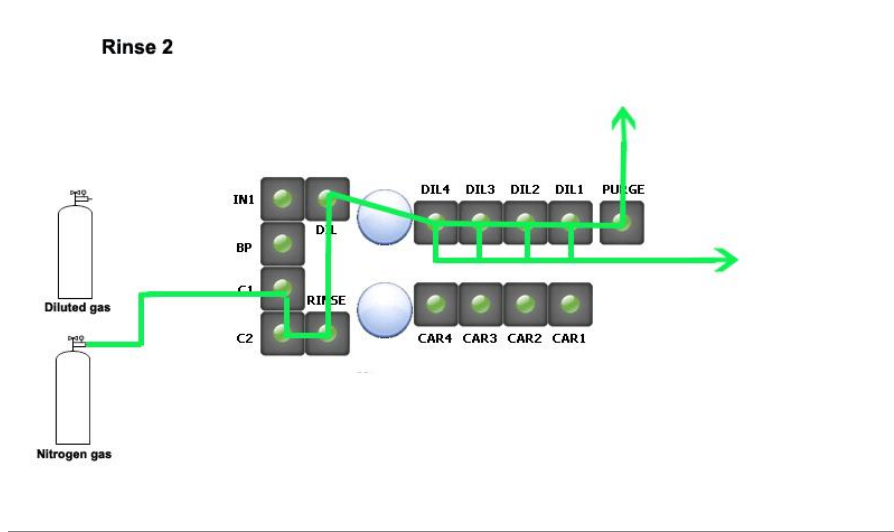

Set date and time sub menu

Set date and time

Set the date

June 2010						
M	T	W	T	F	S	S
31	1	2	3	4	5	6
7	8	9	10	11	12	13
14	15	16	17	18	19	20
21	22	23	24	25	26	27
28	29	30	1	2	3	4
5	6	7	8	9	10	11

Time

4:09:09 PM

Set the time

Validate your choice

Apply

LNS intervention sub menu

This sub menu contains all information about the critical parameters of the SONIMIX : Flow values of the Nozzles, pressure values, polynomial corrections, alarm tolerances. With the code "1219" you can consult the values but not modify them. ONLY LNI Schmidlin SA person can modify the parameters.

LNI - Schmidlin SA Intervention

Unlocking code

Enter the code "1219"

1	2	3	Esc
4	5	6	Del
7	8	9	↵
• 0	←	→	

Factory settings

Nozzle	Flow	Pressure	
1	2.5	1800.1	
Pynomial	Point	Pressure	
DIL_POINT1	1	1840	
Flow Line	Point	Flow	
DIL 1x10	0	0	
Sensor	Gain	Offset	Value
DIL	4	-24	-24
Alarm	Threshold	Delta	
DIL	1800	200	
Option	Enable		
Ouptut Pres.	OFF		

Unit: [mBar], [ml/min], [°C]

Configuration sub menu

This sub-menu gives information about the configuration of your device (type of device, serial number, Model, # of points, # of diluted inputs, if the Nox converter tester is installed, production date and software version. ONLY LNI Schmidlin SA person can modify the parameters.

SX2106 Configuration

Name	SX2106
Serial number	3039
Model	Standard
Point	16
Input	2
NOX	OFF
Production date	12/3/2009
Software version	1.00

ONLY LNI Schmidlin SA person can modify the parameters.

RS 232 sub menu

This menu is able to parameter and test the RS 232 setting.

RS232

Baud Rate: 9600

Data Bits: 8

Stop Bit: 1

Parity: None

Test

The RS 232 has the “AK protocol”

TCP/IP sub menu

This menu is able to parameter and test the TCP/IP setting.

TCP/IP

Use DHCP:

IP Address: 192.168.200.106

Subnet Mask: 255.255.255.0

Default Gateway: 192.168.200.1

Test

Pinged successfully, 2 ms.
Pinged successfully, 1 ms.
Pinged successfully, 1 ms.
Pinged successfully, 1 ms.

The Ethernet has the “AK protocol”
The UDP port is fixed at “9880”

THE TOOLS MENU

The tools menu gives the possibility to access to the history of the gas divider, to open and closed valves individually, to test if the boards are well connected and to transfer data from or to the SONIMIX Gas Divider.

The image displays the 'Tools' menu and four sub-windows:

- History:** A window with a yellow title bar and an empty text area, indicating no history is currently recorded.
- Test EV:** A window with a yellow title bar showing a control interface for valves. It includes a 'Time' field (0:56:26 PM), a 'Date' field (6/19/2019), and a 'Temperature' field (-5.7°C. Below these are two rows of valve controls labeled 'EV Pressure' and 'CAM Pressure', each with four individual valve icons.
- Transfer:** A window with a yellow title bar containing two buttons: 'To USB Drive' and 'From USB Drive', each accompanied by a USB drive icon.
- Test I2C:** A window with a yellow title bar showing a text box with the following text: 'Found Device on Address 0x80', 'Found Device on Address 0x8B', and 'Found Device on Address 0xA2'. Below the text box is a 'Test' button with a 'BUS' logo.

Arrows from the 'Tools' menu point to each of these sub-windows:

- 'History' points to the History window.
- 'EV Test' points to the Test EV window.
- 'Transfer' points to the Transfer window.
- 'Test I2C' points to the Test I2C window.

Show the history of the Gas divider

Open and close the requested valve

Transfer data from or to the gas divider

Test the internal bus

The history Sub-Menu

This sub menu gives all the status that have been performed by the SONIMIX. All the alarms are also documented. This sub menu is very important for our service people in order to understand what has happened with the SONIMIX.

We strongly recommend not to delete the history.

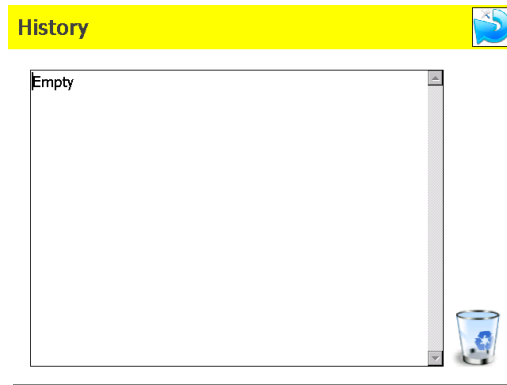

Test EV Sub-Menu

This menu is from interest if you suspect that some electro valve is not opened correctly. You can check the opening or close of each valve individually.

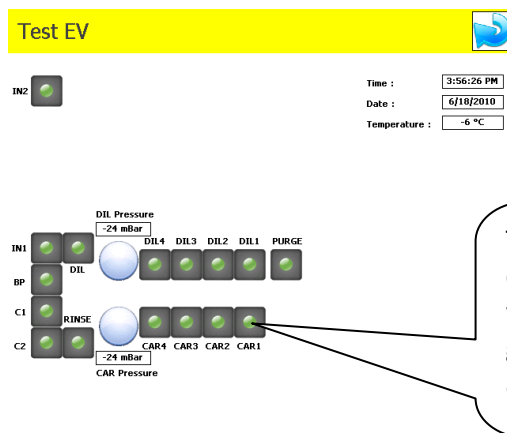

Test I2C Sub-Menu

This sub menu is used to test the I2C bus.

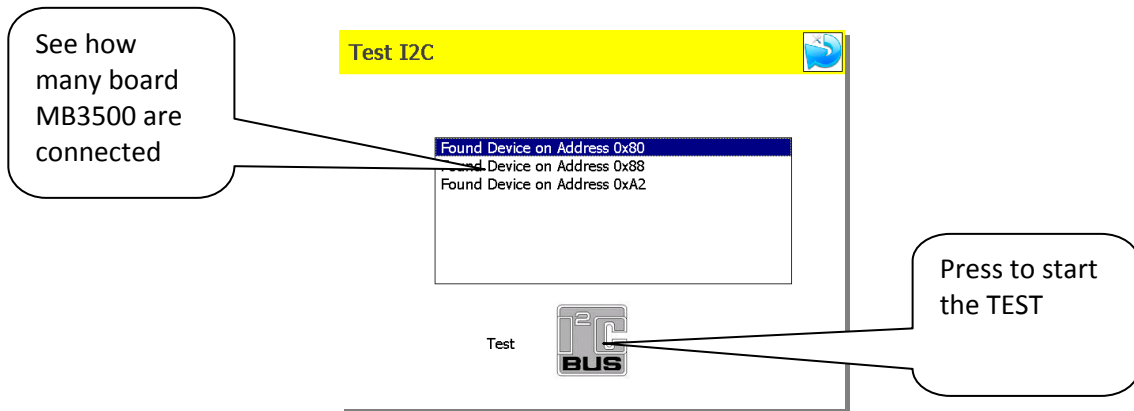

Transfer Sub-Menu

This board can be used in different cases :

- To download the parameters form the SONMIX to the USB

- To download the parameter (software update or parameters) from the USB to the SONIMIX



In any cases, plug the USB key before you touch the icon

If you download to the USB key, a SONIMIX folder will be crated :

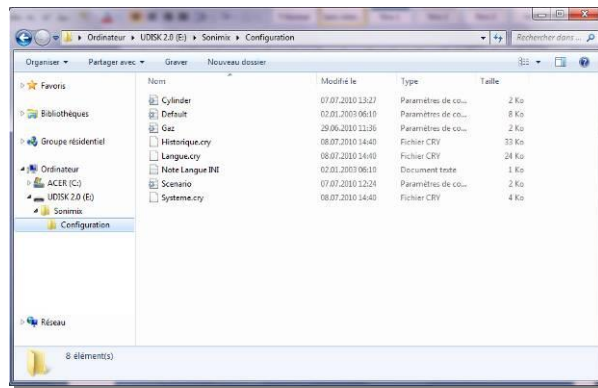

ZIP this folder and send it to our service department.

MAINTENANCE

The SONIMIX 2106-LCD as the other LNI instruments, if they are used in accordance with the manufacturer recommendations, **does not requires regular maintenance**. The major sources of problems being due to the poor quality of the alimenting gases, we recommend to check and to exchange regularly the input filters.

SOFTWARE UPDATE

To upgrade Sonimix software using USB Flash Disk/ Flash Drive - Step by Step Guide

1. Copy folder "SONIMIX" to USB Flash Drive Disk
2. Turn off SONIMIX
3. Insert you Flash Drive to your SONIMIX USB drive port.
4. Then start SONIMIX , please wait the end of loading boot screen before disconnecting USB Flash Drive.

RECALIBRATION

The SONIMIX 2106-LCD is a reference instrument which was carefully calibrated with high precision flowmeters. An ISO 17025 calibration certificate is also available, as LNI Schmidlin SA is an accredited company for Flow measurements.

We recommend to recalibrate the instrument it every 18 months. For this process, we recommend to send the instrument back to LNS



All certificate are available on our web site : www.LNSGAS.com

TROUBLESHOOTING

PROBLEM	MAIN POTENTIAL CAUSE	CORRECTIVE ACTION
Gas Divider		
Input pressure ALARM activated	<ol style="list-style-type: none"> 1. The input pressure of one or both lines is under the minimum value of 2.5 bar 2. The internal alarm wiring is interrupted 	<ol style="list-style-type: none"> 1. Increase the faulty line to a value of minimum 2.5 bar with flow (suggested setting point: dilution step 8) 2. Call your maintenance Dpt.
Insufficient flow at the input of your process (analyzer)	<ol style="list-style-type: none"> 1. An important part of the flow is directed to the by-pass 2. There is a leak between the gas divider and the process 	<ol style="list-style-type: none"> 1. The outlet pressure is more important than the setting value of the back pressure regulator (910 mbar) Modify the alimentering pressure of the process. Verify that there is no additional restriction between the gas divider and the process 2. Verify the tightness of all fittings and organs from the outlet of the gas divider to the process.
Poor quality of mixture's concentration	<ol style="list-style-type: none"> 1. One or all nozzles have been damaged by dust or corrosive gas 2. On or all electro valve cannot open. 3. The by-pass outlet is obstructed 	<ol style="list-style-type: none"> 1. Call your maintenance Dpt. 2. Call your maintenance Dpt. 3. Verify that this outlet is close to the atmospheric pressure
No power supply, revealed by absence of message on the display	1 The fuse is melted or the line voltage is wrong	1. Verify the line voltage and change the fuse. If the fuse fails repeatedly, the problem is probably more important. Please call your maintenance Dpt.
NOX converter tester :		
No flow at the outlet	The valves do not open	Check the Nox converter power supply
No Ozone (NO ₂)	<ol style="list-style-type: none"> 1. UV lamp is damaged 2. NO_x power supply is damaged 	<ol style="list-style-type: none"> 1. Replace the UV lamp 2. Replace the transformer of the power supply.

REMOTE COMMAND

HYPERTEXT TRANSFER PROTOCOL

The Hypertext Transfer Protocol (HTTP) is an application protocol for distributed, collaborative, hypermedia information systems. Hypertext is a multi-linear set of objects, building a network by using logical links (the so-called hyperlinks) between the nodes (e.g. text or words). HTTP is the protocol to exchange or transfer hypertext. HTTP functions as a request-response protocol in the client-server computing model. The client submits an HTTP request message to the server. The server performs functions on behalf of the client, returns a response message to the client. The response contains completion status information about the request and may also contain requested content in its message body. It means that **the server will close the TCP connection immediately after the transfer of this response.**

AK PROTOCOL

The remote command protocol is the AK-Protocol, mainly used in the Automotive Industry. This chapter is not intended to describe all functions and particularities of the protocol, but only to present briefly the instructions installed in the gas divider. For complete information about the AK protocol, the reader has to refer to the "official" documentation.

Syntax

The speed of communication between the Host computer and the SONIMIX 2106-16+NOx is low (frequency < 10Hz).

The principle of communication is based on the Master-Slave relation; the Host Computer (the Master) sends a message to the gas divider (the Slave), the Slave executes the instruction and sends an acknowledgment. The Slaves never requests the communication to the Master.

The instructions are **transmitted to the instrument** with the following syntax :

- * 1 byte : start of the message : STX
- * 1 byte : Don't care word
- * 4 bytes : function code (4 characters)
- * 1 byte : blank
- * 2 bytes : channel number :K0 (see **)
- * N bytes : data if necessary
- * 1 byte : end of message : ETX

The instructions are received from the instrument with the following syntax (answer to the MASTER):

- * 1 byte : start of the message : STX
- * 1 byte : Don't care word
- * 4 bytes : function code (4 characters): ???? if the command is unknown by the Slave
- * 1 byte : blank
- * 1 byte : error status : 0 if no error was detected
- * N bytes : data if necessary
- * 1 byte : end of message : ETX

** to select the channel number :

General 

Channel Number used for the RS 232 AK protocol

Alarms Purge [1]

Languages Purge [2]

Backlight Rinse [1]

History Rinse [2]

Pressure Unit Temperature Unit

Channel

Error Handling

It might happen that an unknown instruction is sent, that the device is busy with a function which is not the desired one, or that an error occurred in the command parameters. This Table summarizes all errors that can appear upon any master instruction.

Device Acknowledgment	Explanation
???? ES	Device does not know the instruction sent.
xxxx ES BS	Device or module is busy with another function or not ready .
xxxx ES SE	Syntax error within command parameters or incomplete command.
xxxx ES NA	Requested function or data are not available.
xxxx ES DF	Data error: The kind or number of given parameters are not valid.
xxxx ES OF	Offline: Device is offline, i.e. Device is in local mode. Only inquiry commands and SREM (set analyzer in remote mode) are allowed.

Where

- xxxx = command
- ES = Error status (see ASTF command for error status description)

K0 is used as standard channel number. If you need to change is you may replace it by K1, K2,...

SRES

Perform a reset. All the defaults values are restored.

Command : SRES K0
Response : SRES ES

Where
ES = Error status (see ASTF command for error status description)

SREM

Activate the Remote command mode

Command : SREM K0
Response : SREM ES

Where
ES = Error status (see ASTF command for error status description)

SMAN

Activate the Manual command mode

Command : SMAN K0
Response : SMAN ES

Where
ES = Error status (see ASTF command for error status description)

STBY

Cancels all running functions (close all the electro-valves) ,set the device to Stand-By and waiting a new command

Command : STBY K0
Response : STBY ES

Where
ES = Error status (see ASTF command for error status description)

ASTF

Return the current alarms values

Command : ASTF K0
 Response : ASTF **ES X Y ... N**

Where

ES = Error status

*The **error status** byte in the acknowledgment telegram signals if internal errors in the device occurred.*

It is zero when no error appeared, and it is unequal zero when one or more errors occurred. Every time a change in the errors happened the error status byte is incremented by one, or when several errors disappeared is decremented by one . Error status byte indicate the real number of errors. If the device does not have errors, the error status byte contains the value 0.

XY ... N = The alarm code

Alarm code :

- 0 if there are no alarms
- 1 if the pressure of the carrier gas is out of range
- 2 if the pressure of the diluted gas is out of range
- 3 if the outlet pressure is out of range
- 4 if the command **SNOX** have been sent before the **SAIR** command

SLST

Open the electro valves in order to perform the selected dilution point

Command : SLST K0 **Arg**
 Response : SLST **ES**

Where

Arg = dilution point

ES = Error status (see ASTF command for error status description)

SSPL

Open the electro valves in order to perform a purge

Command : SSPL K0
 Response : SSPL **ES**

Where

ES = Error status (see ASTF command for error status description)

SRUC (HCL)

Open the electro valves in order to perform a purge with the carrier gases

Command : SRUC K0
Response : SRUC ES

Where

ES = Error status (see ASTF command for error status description)

SVIO

Select the desired diluted inlet (if the option is installed).

Command : SVIO K0 **Arg**
Response : SVIO **ES**

Where

Arg = 1 for the selection of dilution port 1
Arg = 2 for the selection of the optional dilution port 2
...
Arg = 26 for the selection of the optional dilution port 26
ES = Error status (see ASTF command for error status description)

AVIO

Read the selected inlet port

Command : AVIO K0
Response : SVIO **ES Arg**

Where

Arg = 1 for the selection of dilution port 1
Arg = 2 for the selection of the optional dilution port 2
...
Arg = 26 for the selection of the optional dilution port 26
ES = Error status (see ASTF command for error status description)

SVOU

Select the desired outlet port (if the option is installed).

Command : SVOU K0 **Arg**
Response : SVOU **ES**

Where

Arg = 1 for the selection of outlet port 1
Arg = 2 for the selection of the optional outlet port 2
...
Arg = 4 for the selection of the optional outlet port 4
ES = Error status (see ASTF command for error status description)

AVOU

Read the selected outlet port

Command : AVOU K0
Response : AVOU **ES Arg**

Where

Arg = 1 for the selection of outlet port 1
Arg = 2 for the selection of the optional dilution port 2
...
Arg = 4 for the selection of the optional dilution port 4
ES = Error status (see ASTF command for error status description)

EFDA

Set the purge time [s]

Command : EFDA K0 **Arg1 Arg2 Arg3**
Response : EFDA **ES**

Where

Arg1 = optional **HCL**, SSPL or SRUC (by diluted or carrier gas)
Arg2 = time for upstream purge [s] (0 to 240)
Arg3 = time for downstream purge [s] (0 to 240)
ES = Error status (see ASTF command for error status description)

AFDA

Read the set purge time [s]

Command : AFDA K0 **Arg1**
Response : AFDA **ES Arg2 Arg3**

Where :

Arg1 = optional **HCL**, SSPL or SRUC (by diluted or carrier gas)
Arg2 = time for upstream purge [s] (0 to 240)
Arg3 = time for downstream purge [s] (0 to 240)
ES = Error status (see ASTF command for error status description)

AGAT

Read the type of gas and the corresponding correction factor of the gases table

Command : AGAT K0

Response : AGAK **ES Gas1 Cf1 Gas2 Cf2 ... GasN CfN**

Where

Gas = the type of gas
Cf = the corresponding correction factor of the gas
ES = Error status (see ASTF command for error status description)

EGAK

Set the values of the inlet gases

Command : EGAK K0 **Gas1 Gas2 Arg [Inlet]**

Response : EGAK **ES**

Where

Gas1 = the carrier gas (only the gases returned by the AGAT command are accepted)
Gas2 = the diluted gas (only the gases returned by the AGAT command are accepted)
Arg = the concentration in ppm of the diluted gas
Inlet = the physical inlet of the diluted gas (facultative)
ES = Error status (see ASTF command for error status description)

AGAK

Return the values of the set inlet gases

Command : AGAK K0

Response : AGAK **ES Gas1 Gas2 Arg [Inlet]**

Where

Gas1 = the carrier gas
Gas2 = the diluted gas
Arg = the concentration in ppm of the diluted gas
Inlet = the physical inlet of the diluted gas
(this parameter is returned only if it has been used in the EGAK command)
ES = Error status (see ASTF command for error status description)

ALST

Reads the dilution ratios in % of the selected dilution gas
(take into account the nature of the inlet gases, EGAK)

Command : ALST K0 **[Point]**
 Response : ALST **ES Point0 Dil0 Point1 Dil1...PointN DilN**

Where

Point = the dilution point (facultative for command)
Dil = the dilution ratios in % [the considered dilution point]
ES = Error status (see ASTF command for error status description)

AKAK

Return the final concentration in ppm of the selected dilution gas
 (take into account the nature and the concentration of the inlet gases, EGAK)

Command : AKAK K0 **[Point]**
 Response : AKAK **ES Point0 Dil0 Point1 Dil1 ... PointN DilN**

Where

Point = the dilution point (facultative for command)
Dil = the concentration in ppm [the considered dilution point]
ES = Error status (see ASTF command for error status description)

ASTZ

Return the status of the instrument

Command : ASTZ K0
 Response : ASTZ **ES Stat1 Stat2**

Where

ES = error status (see ASTF command for error status description)
Stat1 =

SREM	Remote mode
SMAN	Manual mode

Stat2 =

STBY	if the device is in the stand-by mode
SLST POINT	if the device is generating a dilution point Where POINT is the actual dilution point in use
SSPL PHASE	if the device is generating a purge Where PHASE is the actual phase in use
SRUC PHASE	if the device is generating a carrier purge Where PHASE is the actual phase in use
SAIR	if the AIR valve is open (NOX option)
SONO	if the NO valve is open (NOX option)
SNOX O3_VALUE	if the device generate O3 (NOX option) Where O3_VALUE is the O3 generated

ADRU

Read the raw pressure values (the unit is defined by the software)

Command : ADRU K0 **[Line]**
Response : ADRU **ES Value1 Value2 Value3**

Where

Line = 1 Read the pressure on the carrier line (facultative)
Line = 2 Read the pressure on the diluted line (facultative)
Line = 3 Read the output pressure (option) (facultative)
Value = The pressure of the corresponding line
ES = Error status (see ASTF command for error status description)

AKEN

Read the string (of max 40 ASCII characters) stored in the EEPROM

Command : AKEN K0
Response : AKEN **ES Message**

Where

ES = Error status (see ASTF command for error status description)
Message = Message is the string of max. 40 ASCII characters

EKEN

Store an string of max 40 ASCII characters in the EEPROM

Command : EKEN K0 **Message**
Response : EKEN **ES**

Where

ES = Error status (see ASTF command for error status description)
Message = Message is the string of max. 40 ASCII characters

APAR

Read the configuration of the device

Command : APAR K0
Response : APAR **ES Arg1 Arg2 ... Argn**

Where

ES = Error status (see ASTF command for error status description)
Argn = The system configuration of the device

ASYZ

Return the date and time of system

Command : ASYZ K0
Response : ASYZ **ES Arg**

Where

ES = Error status (see ASTF command for error status description)
Arg = Date and time in format "**yyMMdd HHmmss**"

ATEM

Read the raw temperature values (the unit is defined by the software)

Command : ATEM K0 [**Line**]
Response : ATEM **ES Value**

Where

Line = 1 Read the internal temperature (facultative)
Value = The temperature of the corresponding line
ES = Error status (see ASTF command for error status description)

EGCF

Set diluted conversion factor (blend gas)

Command : EGCF K0 **Arg**
Response : EGCF **ES**

Where

Arg = Conversion factor for blend gas

ES = Error status (see ASTF command for error status description)



a.) To calculate the concentration (ALST or AKAK instruction) values with the blend as conversion factor, the EGCF argument value (CF) must be > 0.

b.) Set to 0, if you want that the Sonimix automatically calculates the CF as long as the gas used have been entered into gas list.

AGCF

Read diluted conversion factor set (blend gas)

Command : AGCF K0

Response : AGCF **ES Arg**

Where

Arg = Conversion factor for blend gas

ES = Error status (see ASTF command for error status description)

SKOP (NOX option)

Active the NOx converter tester

Command : SKOP K0

Response : SKOP **ES**

Where

ES = Error status (see ASTF command for error status description)

SVSA (NOX option)

Open functions for the NOx converter tester

Command : SVSA K0 **Arg**

Response : SVSA **ES**

Where

Arg = 101 generate the ozone (the last value set by software)
Arg = 102 switch on the AIR valve (like SAIR)
Arg = 103 switch on the NO valve (like SONO)
ES = Error status (see ASTF command for error status description)

SVSZ (NOX option)

Close functions for the NOx converter tester

Command : SVSZ K0 **Arg**
Response : SVSZ **ES**

Where

Arg = 101 stop the ozone
Arg = 102 switch off the AIR valve (like SAIR)
Arg = 103 switch off the NO valve (like SONO)
ES = Error status (see ASTF command for error status description)

SONO (NOX option)

Open or close the valves in order to perform the NO phase of the NOx converter tester

Command : SONO K0 **Arg**
Response : SONO **ES**

Where

Arg = 1 Open the valves
Arg = 0 Close the valves
ES = Error status (see ASTF command for error status description)

SAIR (NOX option)

Open or close the valves in order to perform the Air phase of the NOx converter tester

Command : SAIR K0 **Arg**
Response : SAIR **ES**

Where

Arg = 1 Open the valves
Arg = 0 Close the valves
ES = Error status (see ASTF command for error status description)

SNOX (NOX option)

Set the ozone in order to generate NO2 phase of the NOx converter tester

Pay attention : the commands **SONO** and **SAIR** must have been sent previously

Command : SNOX K0 **Arg**
Response : SNOX **ES**

Where

Arg = desired NO2 value (0 = minimal value and 100 = maximal value)
ES = Error status (see ASTF command for error status description)

ANOX (NOX option)

Read the set ozone value

Command : ANOX K0
Response : **SNOX ES Arg**

Where

Arg = desired NO2 value (0 = minimal value and 100 = maximal value)
ES = Error status (see ASTF command for error status description)